

**commodore**

PRINTER

MODEL

MCS 820

Printer Handbook



*The Commodore MCS 820 printer is physically and functionally the same as the Okimate 20 printer. All ongoing reference to the Okimate 20 should be regarded as the same as the Commodore MCS 820 for the remainder of this manual.*

*When ordering consumables or accessories from your dealer for your Commodore MCS 820, please use the following part numbers:*

<i>Roll paper stand</i>	<i>270830</i>
<i>Roll thermal paper</i>	<i>280003</i>
<i>Black ribbon</i>	<i>280001</i>
<i>Colour ribbon</i>	<i>280002</i>

**commodore**

PRINTER

MODEL

MCS 820

**Printer Handbook**

 **commodore**





# CONTENTS

## Section 1: SETTING UP — Get the basic facts on setting up and operating your printer

Introduction .....	1
Getting Started .....	2
Inserting ribbon .....	3
Inserting paper .....	6
Running a self-test .....	9
Connecting your OKIMATE 20 to your computer .....	10
More about OKIMATE 20 .....	10
Control panel .....	11
Other controls .....	12
Choosing the proper paper .....	12
Inserting computer paper .....	13
Inserting single sheets .....	15
Using roll paper .....	16
Paper sizes .....	19
Removing the control module .....	19

## Section 2: SOFTWARE & PROGRAMMING

Introduction .....	21
Printing with software packages .....	21
Printing with flair .....	22
Programming on your own .....	22
Programming BASICS .....	26
Character size .....	26
Double-width printing .....	27
Print quality .....	29
Italics .....	30

Underlining .....	31
Superscripts/Subscripts .....	32
IBM character sets .....	33
CHARACTER SET 1 .....	34
CHARACTER SET 2 .....	35
Line spacing .....	36
Fine line spacing .....	39
Line feed .....	42
Horizontal tabs .....	43
Form feeds, page length .....	45
Perforation skipping .....	46
Cancel function .....	46
Power-up features .....	47

## Section 3: ADVANCED PROGRAMMING

Introduction .....	49
Custom Characters .....	49
Designing a character .....	49
Ascenders and descenders .....	51
Loading the data .....	51
Printing the character .....	52
Exiting the custom character set .....	53
Graphics .....	55
Creating your graphics .....	56
8-dot graphics .....	58
24-dot graphics .....	63
Color Printing .....	66
Color shading (experts only) .....	68

1

2

3

4

App.

## **Section 4: PRINTER CARE & TROUBLE SHOOTING —**

How to clean and maintain your OKIMATE 20,  
and what to do if problems ever crop up

Introduction .....	71
Cleaning Up .....	71
Replacing the Printhead .....	74
Troubleshooting Guide .....	75
What happens if .....	75

## **Appendix A : FUNCTION SWITCH SETTINGS AND INTERFACING .....**

77

Switching Settings .....	77
To set the function switches .....	78
Standard switch setting at delivery time .....	80
Switch settings for serial interface .....	81
Interfacing .....	82
Cable requirements .....	82
Parallel interfacing .....	82
Serial interfacing .....	85

## **Appendix B : SPECIFICATIONS .....**

87

## **Appendix C : PROGRAMMER'S GUIDE .....**

89

## **Quick Reference**

## Section 1: SETTING UP

### Introduction

1

Whatever your printing needs, OKIMATE 20 meets the challenge like a professional. OKIMATE 20 is easy to use, but gives you advanced printing features you'd expect from much larger, more expensive printers. Write crisp, clear letters; get a quick program listing, or print charts, graphs and illustrations. You can underline words, print them in italics, or write them in eye-catching "headlines."

And there's more. OKIMATE 20 gives you a feature the OKIMATE family of printers is known for: it lets you print graphics or test in bright, glossy color. All these features make the OKIMATE 20 the perfect partner for your IBM PC, PC/XT, or PC Jr.

Section 1 of this handbook tells you how to set up OKIMATE 20, connect it to your IBM computer, and take it for a "test drive." It also gives details on operating the printer, and what type of paper to use.

Section 2 tells how to work with your printer on a day-to-day basis. It gives information on running this printer with software packages and fills you in on details of programming. This section explains many of OKIMATE 20's printing features.

For more advanced features, read Section 3, which explains how to program graphics, custom designed characters, and color printing.

Finally, Section 4 of this handbook gives cleaning, maintenance and troubleshooting information.

Here's what you need to start printing:

- Your printer, of course
- Interface cable
- This printer handbook
- Black ribbon
- Color ribbon
- Paper

## Getting Started

Before you begin setting up OKIMATE 20, take a quick look at the printer and become familiar with the components and printer controls shown here. Later, we'll explain each of these in more detail.

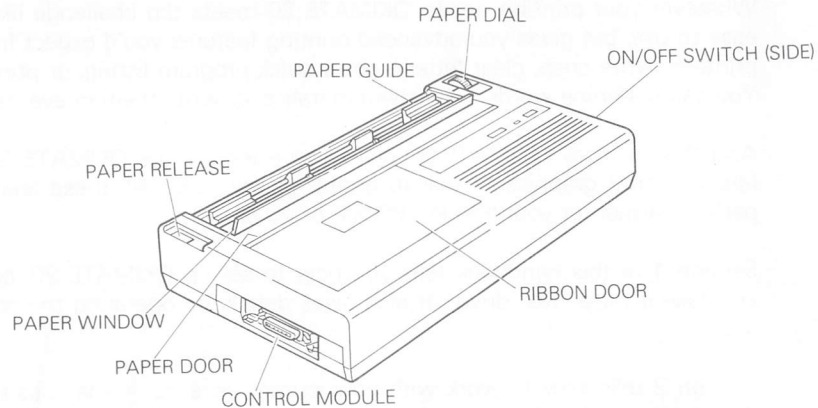

The **CONTROL PANEL** buttons let you activate the printer and control print darkness. The **READY** light tells you if your printer is ready to print, and signals you if there's a printing problem, like running out of ribbon or paper.

The **PAPER DOOR** and **PAPER WINDOW** open to allow you to insert paper and change the printhead. Open the **RIBBON DOOR** to change the ribbon.

You can manually advance paper using the **PAPER DIAL**. The **PAPER RELEASE** disengages the paper advancing mechanisms so you can insert paper easily.

The **CONTROL MODULE** serves as the interface between the computer and the printer. This fits in the **MODULE SLOT**, and is covered by the **LOCKING COVER**. The locking cover also serves as a tool for removing the control module.

The PAPER GUIDES adjust to accommodate different sizes and types of paper.

Now you're ready to set up OKIMATE 20 and get a quick printing demonstration by running a self test.

## ***Inserting ribbon***

Then insert the black ribbon by following these steps:

- 1) Open the paper and ribbon doors.

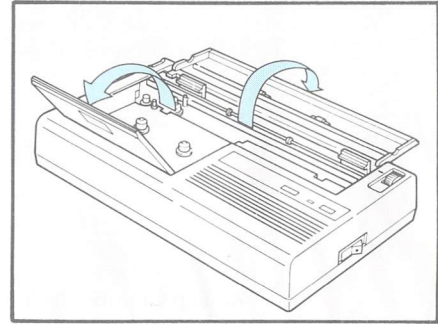

- 2) Remove the clip from the black ribbon cartridge and turn the blue thumb dial counter-clockwise to take up slack.

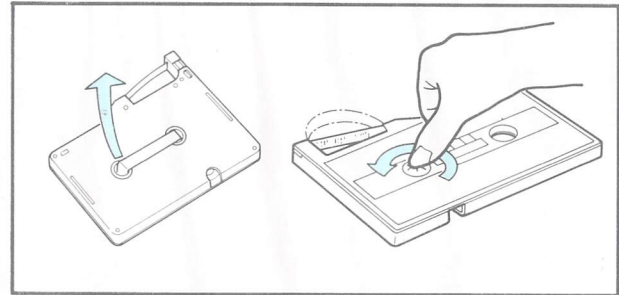

- 3) Move the printhead carriage all the way to the left. Hold the printhead carriage between your thumb and index finger, and then gently pull it back until it locks with a "snap."

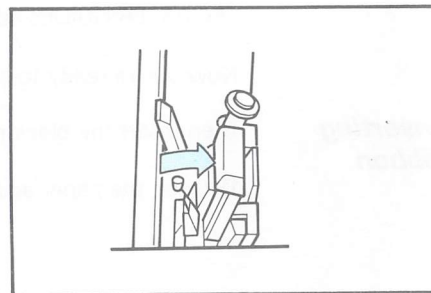

- 4) Slip the ribbon in front of the printhead.

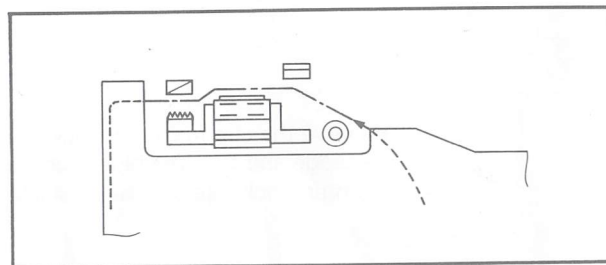

- 5) Lower the ribbon cartridge into the ribbon compartment.

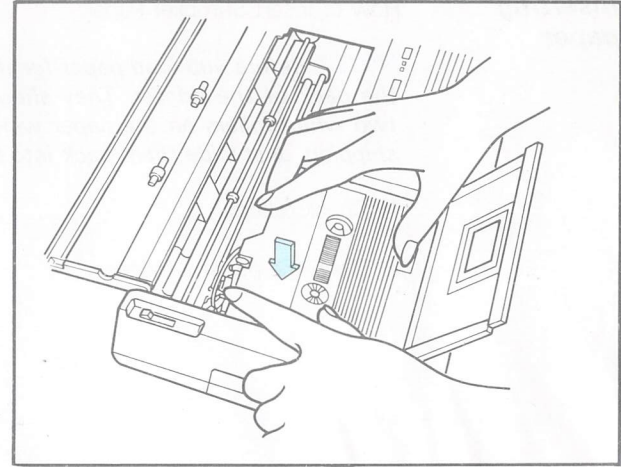

- 6) Gently push the printhead carriage forward to its upright position. Close the ribbon and paper doors.

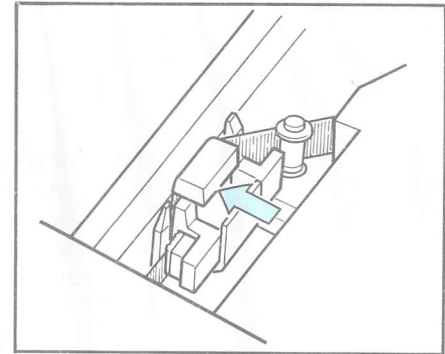

**CAUTION:** When changing ribbon or paper after printing, allow a few minutes for the printhead to cool before touching it.



## Inserting paper

How to Insert Sprocket Paper:

**NOTE:** Before you load paper for the first time, look at the black plastic rollers in the paper slot at the back of the printer. They should be about the same distance from the printer's sides as the two white rollers on the paper window. These black rollers sometimes shift out of position during shipping. Just slide them back into place — that will make paper loading easier.

- 1) Check rollers.
- 2) Open the paper window.

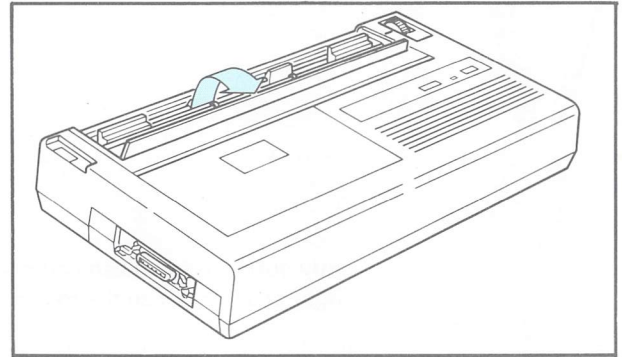

- 3) Align the border (sprocket) holes with the round outer marks on the paper guides. If necessary, move the right paper guides by snapping it towards you and then slide it to the left or right as needed.

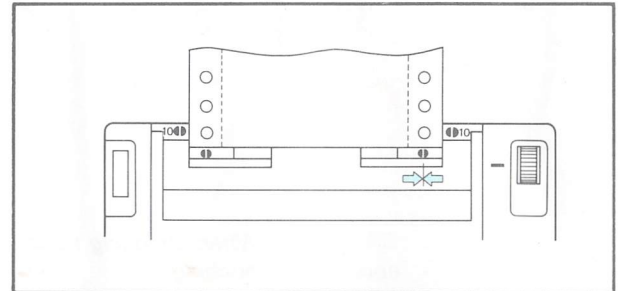



4) Snap them back again to lock it.

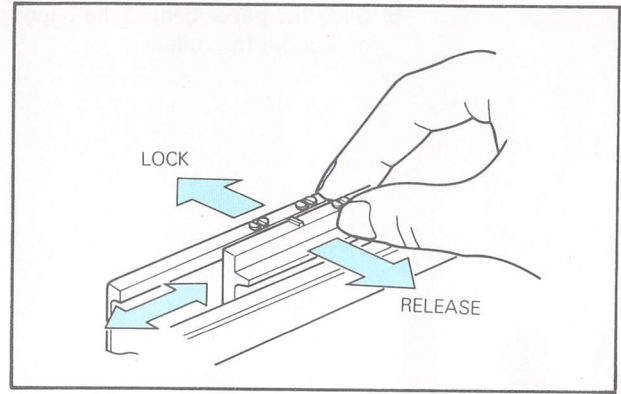

1

5) Open the paper release.

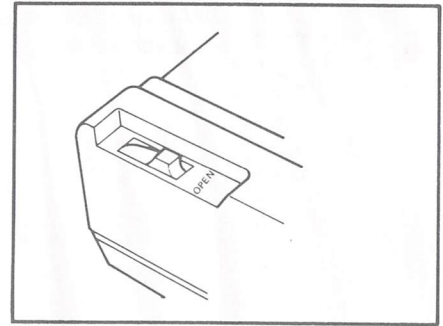

- 6) Slide the paper behind the paper guides and under the rollers.

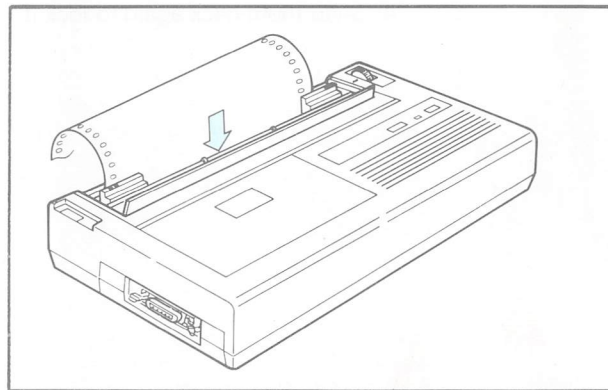

- 7) Advance the paper with the paper advance knob.

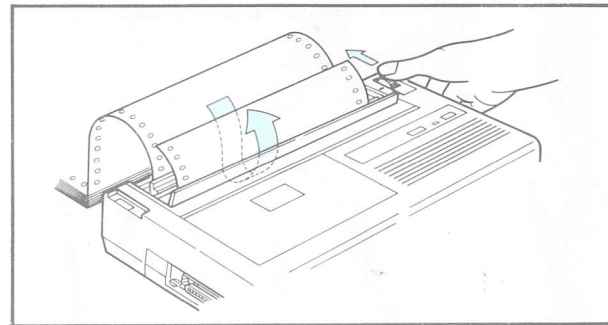

- 8) Gently pull the printhead carriage back to make sure the ribbon is still in place. Close the paper window.

## Running a self-test

**CAUTION:** ALWAYS make sure the printer's ON/OFF switch is OFF before plugging it in. (Otherwise, a sudden power surge could cause damage).

- 1) Plug the printer into a grounded electrical outlet. DO NOT use a conversion plug — like an extension cord — which ignores the ground.

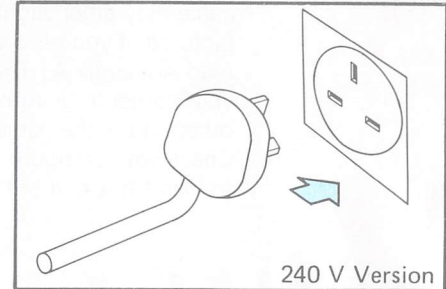
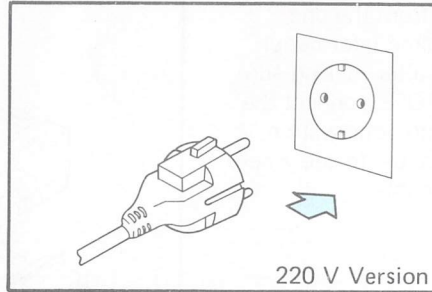

- 2) At the same time, turn on the printer and press the SELECT button. When you release the SELECT button, the printer will start printing a test pattern:

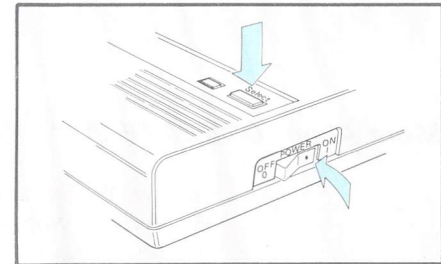

```

○ !"#$%&'()*+,-./0123456789:;<=>?@ABCDEFGHIJKLMNopQRSTUVWXYZ[\]^_`abcdefghijklmnop ○
○ !"#$%&'()*+,-./0123456789:;<=>?@ABCDEFGHIJKLMNopQRSTUVWXYZ[\]^_`abcdefghijklmnop ○
○ !"#$%&'()*+,-./0123456789:;<=>?@ABCDEFGHIJKLMNopQRSTUVWXYZ[\]^_`abcdefghijklmnop ○
○ !"#$%&'()*+,-./0123456789:;<=>?@ABCDEFGHIJKLMNopQRSTUVWXYZ[\]^_`abcdefghijklmnopqr ○
○ !"#$%&'()*+,-./0123456789:;<=>?@ABCDEFGHIJKLMNopQRSTUVWXYZ[\]^_`abcdefghijklmnopqrs ○
○ !"#$%&'()*+,-./0123456789:;<=>?@ABCDEFGHIJKLMNopQRSTUVWXYZ[\]^_`abcdefghijklmnopqrst ○
  
```

- 3) To stop the test, turn the printer OFF.

reduced by 65%

**Connecting  
your  
OKIMATE 20  
to your  
computer**

1

**CAUTION:** *Don't plug in your printer just yet. We'll tell you when you can.*

Plug the data cable into your printer. (Your cable may differ slightly from the one pictured. If you need cabling information, read Appendix A.) Then, after making sure your computer is turned OFF, connect the other end of the cable into your system. Check your computer manual to see where to insert this end of the cable.

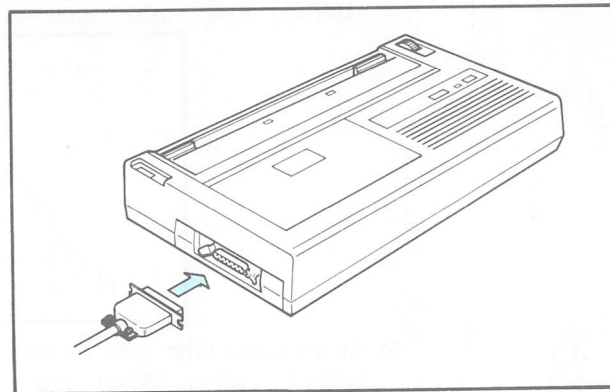

**More About OKIMATE 20**

Here, we'll take a detailed look at your OKIMATE 20. This section explains where to use your OKIMATE 20, what its controls and indicators do, what kind of paper it uses and where to buy it.

Your OKIMATE 20 can work right alongside your computer. Keep it on a flat surface (a desktop will do), within reach of your computer and a grounded electrical outlet. If you're using computer paper, allow at least 12 inches of space behind the printer so you can stack the paper. If you're installing the optional roll paper stand (more on that later) allow at least 6 inches.

## Control panel

OKIMATE 20's control panel contains a DARKNESS control, a SELECT button and an READY LIGHT.

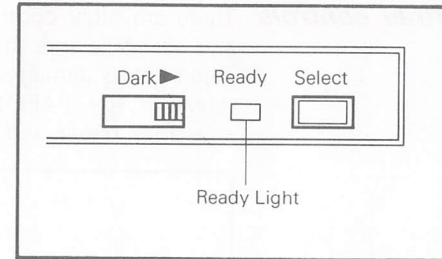

Slide the DARKNESS control to lighten or darken printing. Experiment with this control to determine which setting is best for your printing needs.

The SELECT button makes OKIMATE 20 pause during printing and then restart. To pause during printing, press the SELECT button down and hold it until the printhead reaches the end of a line. (The printer looks for a pause signal at the end of each line.) When a pause occurs, release the SELECT button and OKIMATE 20 will stop printing. (In color printing, this pause won't go into effect until all three colors have been printed.) When the printer pauses, the READY light will start to blink slowly. To restart the printer after a pause, press SELECT again.

The READY LIGHT indicates your printer's operating status:

- A steady light means OKIMATE 20 is printing or ready to receive data.
- A slow blink means the printer has paused, or you need to insert more paper or ribbon.

**Other controls**

There are other controls on your OKIMATE 20. The ON/OFF SWITCH, obviously, turns the printer on and off. Make sure this switch is OFF when plugging in your printer, otherwise, a sudden power surge could cause damage. The PAPER DIAL moves the paper. Turn it away from you to move the paper forward. The PAPER RELEASE disengages the paper advance mechanism. OPEN to insert or straighten paper, and CLOSE for printing.

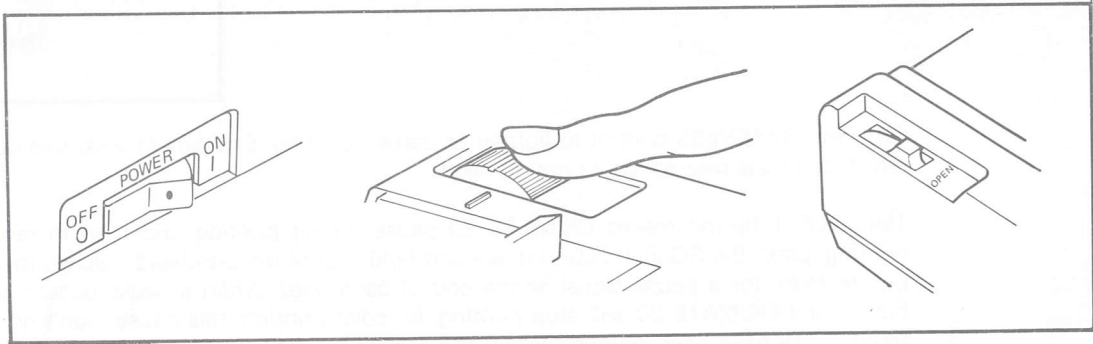
**Choosing the proper paper**

OKIMATE 20 is a thermal transfer printer. It prints using 24 tiny heat elements located on OKIMATE's printhead. These elements press against the ribbon, which is coated with a wax-like substance. When an element heats up, the ribbon coating melts onto your paper, forming a series of tiny dots that make up a character.

Each of your OKIMATE 20's characters is produced by a unique pattern of these dots.

Some types of paper work better than others for thermal transfer printing. When you're using your OKIMATE 20 like a typewriter to print letters or reports, just about any kind of paper works well...except for paper with rag content, like typewriter bond with cotton fiber content and erasable bond.

When you're printing artwork, graphics, and charts, however, smooth paper works best. You might want to experiment with various paper types and see what suits your needs best.

You can print on acetate sheets up to .0013 mm thick for transparencies. Scotch/3M Transparency Note Pad works well, as do extra-thin (.0008 mm thick) transparencies.

Your OKIMATE 20 can even print without a ribbon if you use thermal paper. This is a special chemically-treated, heat sensitive paper available at many computer stores and some stationery stores. To use thermal paper, remove the ribbon, insert the thermal paper, and print normally.

You can use computer paper, roll paper, or single sheet paper with OKIMATE 20. "Computer paper" has holes along its border so gears in the printer can advance it. Single sheets, like standard typewriter paper, are fed individually. Attach an optional roll stand to feed continuous roll paper.

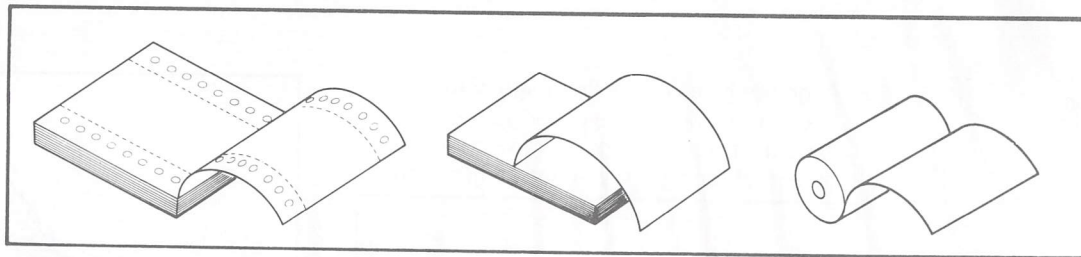

### ***Inserting computer paper***

If you're using computer paper, place a small stack on the table behind the printer or place a carton of paper on the floor behind the printer.



1) Open the paper window.

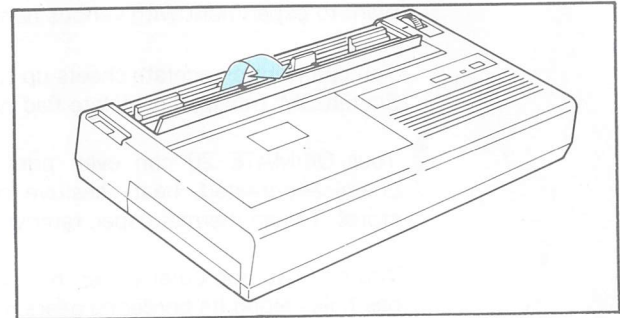

2) Align the holes of the first page with the outer marks on the paper guides. Snap the right paper guide forward and slide it left or right if you need adjustments.

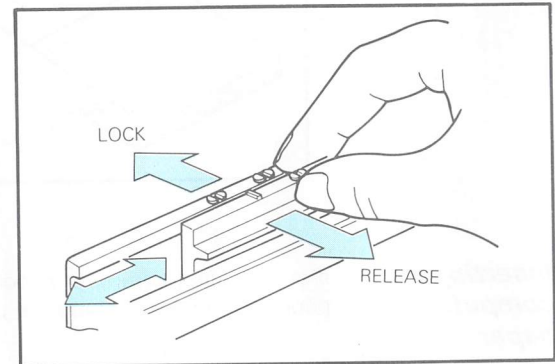
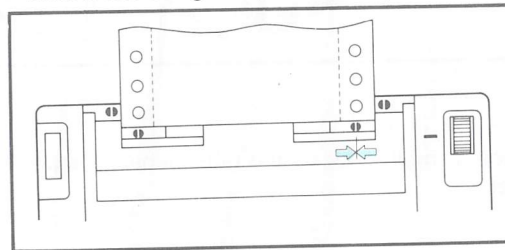



- 3) Open the paper release and insert the paper behind the paper guides and advance it by turning the paper dial. Close the paper window, and straighten the paper if necessary by opening the paper release.

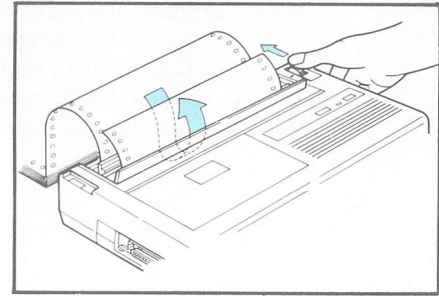

### ***Inserting single sheets***

- 1) Open the paper window and align the edges of the paper with the inner marks on the paper guides. Adjust the right guide if necessary.

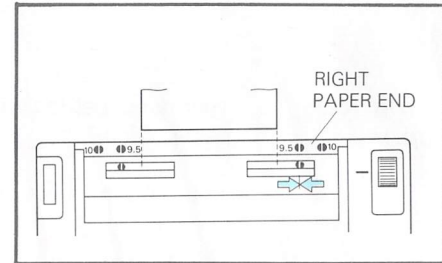

- 1
- 2) Insert the paper behind the paper guides and advance the paper with the paper dial. Close the paper window, and straighten the paper if necessary by opening the paper release.

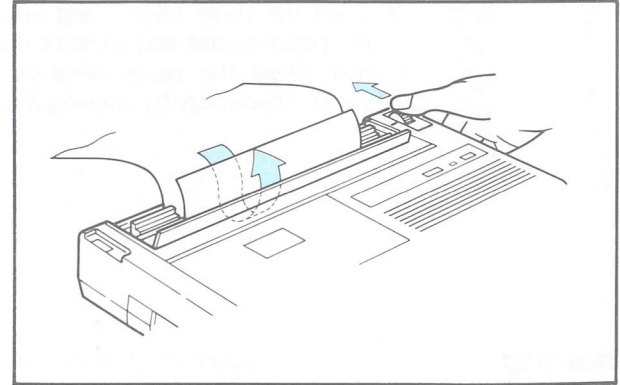

### ***Using roll paper***

Thermal paper (as well as normal paper) is often sold in rolls. To use roll paper, install the optional roll paper stand.

- 1) Lift up the arms on the roll paper stand.

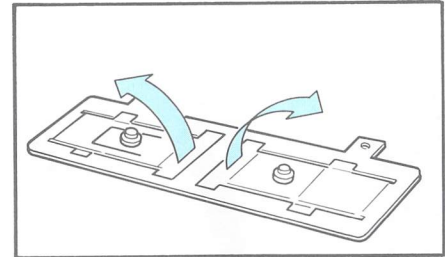

2) Fold each arm along the lines shown.

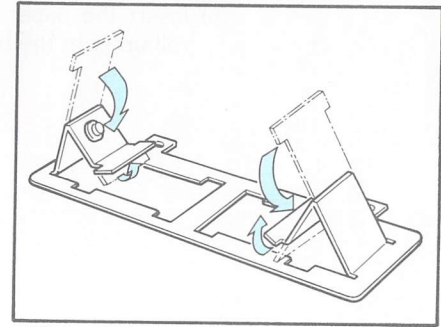

3) Snap the holes on the bottom of the arms onto the tabs protruding from the base of the stand. The folded arms should now stand up by themselves.

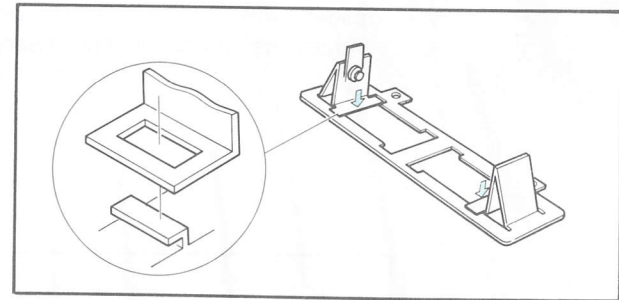
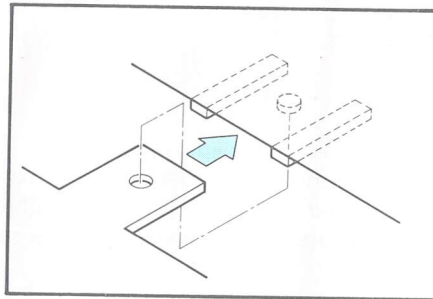

4) Find the two slots on the bottom of the printer. Fit the roll stand tabs into these slots and lower the printer so the printer sits on top of the tabs.

- 5) Insert the paper roll on the stand. The paper should roll up from the bottom.

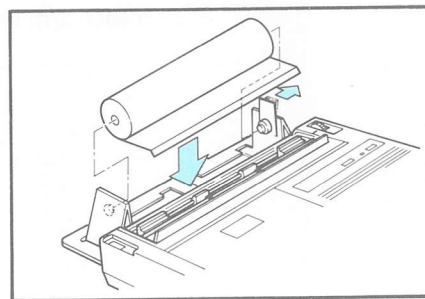

- 6) Open the paper window and align the edges of the paper with the inner marks on the paper guides. Adjust the right guide if necessary.

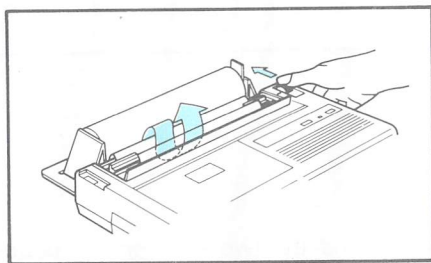
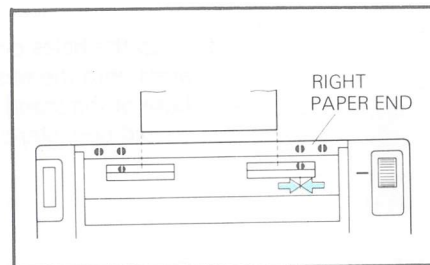

- 7) Insert the paper behind the paper guides and advance the paper with the paper dial. Close the paper window, and straighten the paper if necessary by opening the paper release.

## Paper sizes

You can print on paper of varying widths. To do this, you may have to adjust the paper guides to fit.

Snap the guides forward, then move them so the left guide positions the left margin and the right guide adjusts to the width of the paper. Snap the guides back to lock.

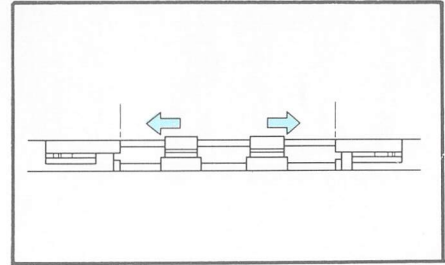

**NOTE:** If you are changing from a narrow width paper to wide paper, slide the paper rollers to accommodate the width of the paper. These black plastic rollers in the paper slot should be about the same distance apart from the printer's sides as the two white rollers on the paper window.

## Removing the control module

If you need to remove the control module to replace it or change switch settings, follow these steps.

- 1) Remove the locking cover.
- 2) Hook the slots on the bottom of the cover into the metal tabs on the end of the cartridge.

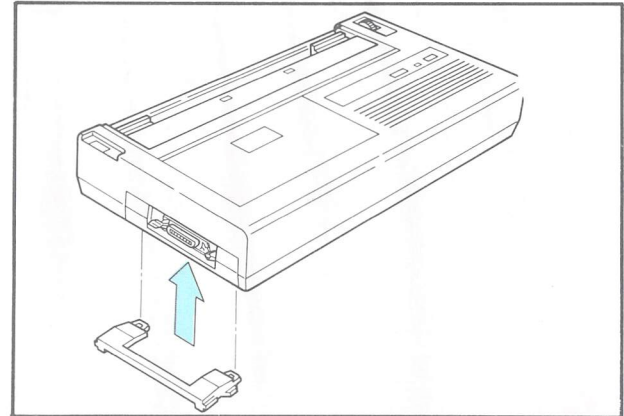

3) Hold the edges of the cover and gently pull out the cartridge.

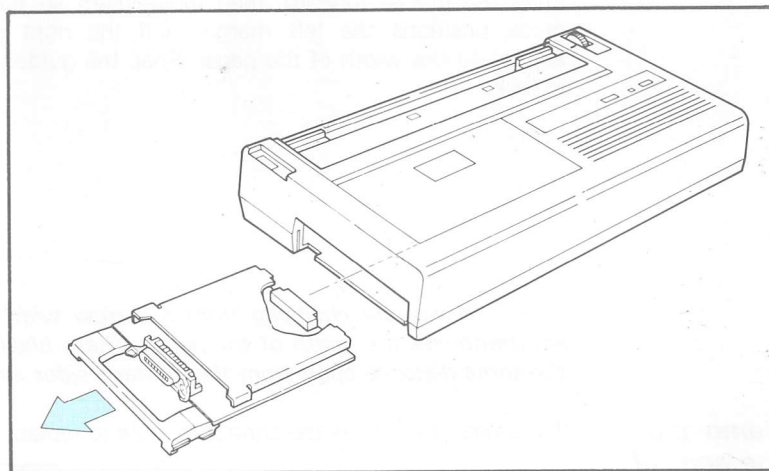

1

## Section 2 – SOFTWARE & PROGRAMMING

### Introduction

Now that you've set up your OKIMATE 20, attached it to your IBM computer and learned how to insert ribbon and paper, it's time to start printing.

So what can you print and how can you print it? By using software packages, you can do a variety of things — print letters with a word processing package, record a permanent tally of figures from a financial package, or reproduce pictures you've drawn with a graphics package. With your own programming in BASIC or another language, you control printing features with special codes. This section tells how to use these codes.

#### ***Printing with software packages***

Most likely, you'll do most of your OKIMATE printing using a software package, like word processing or financial spreadsheets. This is easy because most packages give you controls for printing, so all you'll need to do is follow the software package's instructions.

Many packages ask you to select which printer you have from a list or "menu." Look for one of these listings in the printer menu:

IBM Graphic Printer  
or  
IBM 5152 Model 2 Printer

Don't choose an OKIMATE 20 selection, since your printer is specially configured for IBM commands.

Some software packages let you use some of your OKIMATE's special features that enable you, for example, to vary printing size and style. If your software package does this (check your software manual), you'll need to know the special codes that control these features — read the foldout reference guide at the back of this book for these codes, and for more detailed information, continue reading this section. Some software packages have special codes that go before OKIMATE 20's



## ***Printing with flair***

printing commands in a file. Others have ways you can assign OKIMATE 20's codes to characters you're not likely to use, like "&" or "@", so you can change printing styles with a single keystroke. Again, read your software manual for these details.

Remember, though, that your software package may not let your printer use all the features its capable of: for example, a spreadsheet program might let you pick a particular style of type for an entire document, but won't let you change back and forth between different features within that document.

OKIMATE 20 is highly talented. You can print text or graphics on black and white or color, vary the size of your printing, underline words, print them in italics, add European language characters, indent, add horizontal and vertical tabs, and more. Just use the codes explained in this section.

If you don't insert any special codes, the OKIMATE 20 has certain standard or, "default," settings for printing. Whenever you turn the printer on without making any special programming changes, it will:

- print text 10 characters per inch (or 17.1 characters per inch if you've adjusted the function switch) and space lines at six lines per inch.
- adjust for paper that's 12 inches long and skip 1 inch over perforations between pages.
- print in either data processing or correspondence quality (depending on function switch settings).

Other features may be added by using function switches or sending program commands. For a full list of power-on settings, see the list at the end of this section.

## ***Programming on your own***

In addition to printing with IBM-compatible software packages, you can change printing features through programming. Throughout this section, we use the BASIC programming language for our examples. Since entire books and college courses teach BASIC, we won't try to tell you everything about the language here, but we will give specific BASIC commands needed for printing. For more details on IBM Personal Computer BASIC, read the BASIC manual of your IBM Personal Computer Hardware Reference Library.



An LPRINT statement tells the computer to send information to your printer. This information could be text, like this:

```
10 LPRINT "Hi, I'm your new printer!"
```

When you send this to your computer, you get a printout:

```
○ Hi, I'm your new printer! ○  
○ ○  
○ ○  
○ ○
```

Another kind of information you send to the printer doesn't print, but changes the way OKIMATE 20 operates, like this:

```
10 LPRINT "Hi, I'm your new printer!"  
20 LPRINT CHR$(14);"Here's double-width"  
30 LPRINT CHR$(20);"Back to normal"
```

```

○                               ○
○ Hi, I'm your new printer!     ○
○ Here's double-width           ○
○ Back to normal                 ○
○                               ○
○                               ○

```

The CHR\$(14) code in line 20 is a non-printing command telling OKIMATE 20 to print in double-width. CHR\$ tells the printer to read the number 14 as an ASCII code number. ASCII (American Standard Code for Information Interchange) is a standard code system used by most computers. In this case, 14 is an ASCII code telling the printer to print in double-width. The CHR\$(20) command in line 30 tells the printer to switch back to normal sized printing — 10 characters per inch.

This CHR\$ format is followed in all the commands explained in this section. Sometimes, for more complex features, OKIMATE 20 uses combinations of ASCII codes. The first code in this combination is CHR\$(27), called the "ESCAPE" code. This code tells the printer to interpret the codes that follow as part of an instruction. For example:

```

10 LPRINT "This code ";CHR$(27);CHR$(45);CHR$(1);"starts underlining ";
20 LPRINT "and this code ";CHR$(27);CHR$(45);CHR$(0);"stops it."

```

○  
○ This code starts underlining and this code stops it. ○  
○ ○  
○ ○

In addition to LPRINT statements, you can also use an OPEN command at the beginning of your program, followed by PRINT # statements whenever you want to print a line. The OPEN command opens a file for output to your printer, and PRINT # statement, used like an LPRINT command specifies that particular file. Here's an example using this OPEN and PRINT combination.

```
10 OPEN "LPT1:" AS #1
20 PRINT #1, "This code"; CHR$(27); CHR$(45); CHR$(1); "starts underlining".
30 PRINT #1, "and this code"; CHR$(27); CHR$(45); CHR$(0); "stops it."
```

This certainly isn't all there is to programming, but it should be enough to get you started as you go through the examples shown for programming features here. If you haven't already, remember to learn your computer's version of BASIC. As you gain more experience, you'll discover your own programming shortcuts and tricks. Once you get the hang of it, it's easy.

Here, you'll learn the control codes needed for everyday printing: changing character size, underlining, printing in italics, and similar features.

### Character size

Function:	Code:
Pica (10 CPI)	CHR\$(18)
Elite (12 CPI)	CHR\$(27); ":"
Condensed (17.1 CPI)	CHR\$(15)

OKIMATE prints characters in three sizes commonly found on typewriters: pica, (10 characters per inch); elite, (12 characters per inch), and condensed (17.1 characters per inch). When you turn your printer on, it automatically prints in pica. Use programming commands to change the size.

```
10 LPRINT CHR$(18);"Here's pica.";
20 LPRINT CHR$(27);":"; "This is elite,";
30 LPRINT CHR$(15);"and here's condensed."
```

```
○ Here's pica. This is elite, and here's condensed. ○
○
○
○
```

## Double-width printing

Function:	Code:
One line only	CHR\$(14)
Cancel	CHR\$(20)
Continuous	CHR\$(27);"W";CHR\$(1)
Cancel	CHR\$(27);"W";CHR\$(0)

Extra! Extra! Your OKIMATE 20 makes headlines. Using the double-width command doubles the width of whatever character size you're printing. Use this feature for headlines, titles, or just to make words stand out. The CHR\$(14) command turns on double-width until the end of the current line. You can cancel it before the end of the line with a CHR\$(20) command.

If you want to print double-width for more than one line, use the CHR\$(27);"W";CHR\$(1) command. This will print double-width continuously until you cancel it with a CHR\$(27);"W";CHR\$(0) command.

```
10 LPRINT CHR$(18);"pica (10 CPI)";CHR$(14);"5 CPI"  
20 LPRINT CHR$(27);".";"Elite (12 CPI)";CHR$(14);"6 CPI"  
30 LPRINT CHR$(15);"Condensed (17.1 CPI)";CHR$(14);"8.5 CPI"  
40 LPRINT CHR$(18);CHR$(14);"This command prints double. . ."  
50 LPRINT "... for one line only."  
60 LPRINT CHR$(27);"W";CHR$(1);"Here's continous"  
70 LPRINT "double width."
```

```
○ pica(10 CPI)5CPI I ○  
○ Elite(12CPI)6CPI ○  
○ Condensed(17.1CPI)8.5 CPI ○  
○ This command points double... ○  
○ ...for one line only. ○  
○ Here's continuous ○  
○ double width. ○  
○ ○
```

reduced by 85%



## Print quality

### Function:

Data Processing (DP)

Correspondence Quality (CQ)

### Code:

CHR\$(27); "I"; CHR\$(1)

CHR\$(27); "I"; CHR\$(2)

When speed is important, use data processing printing at 80 characters per second for program listings and quick printouts. When quality counts, use correspondence quality for crisp, clear printing of letters and other important documents. This prints 40 characters each second.

CQ prints in either pica or elite (standard and double-width), but it won't work with condensed printing or super/subscripts. If you send a CQ command while you're printing in one of these styles, the CQ won't start until you return to pica or elite.

```
10 LPRINT CHR$(27); "I"; CHR$(1); "Data processing prints fast."  
20 LPRINT CHR$(27); "I"; CHR$(2); "Correspondence quality is sharp."
```

```
○  
○ Data processing prints fast. ○  
○ Correspondence quality is sharp. ○  
○ ○
```

**PROGRAMMER'S NOTE:** The correspondence quality mode replaces the emphasized and enhanced modes on IBM printers. If your software sends OKIMATE 20 a command for emphasized or enhanced (CHR\$(27); "E" or CHR\$(27); "G"), then OKIMATE 20 will print in correspondence quality instead.

## Italics

Function:

Start Italics

Stop Italics

Code:

CHR\$(27);"%G"

CHR\$(27);"%H"

To add emphasis to a word or phrase, print characters in Italics. This slants the characters to make them stand out. You can print Italics in pica or elite printing (standard and double-width), but not condensed or super/subscripts. If you send an Italics command while printing one of these styles, it won't start until you've returned to pica or elite.

```
10 LPRINT CHR$(18);"Everyday pica.";  
20 LPRINT CHR$(27);"%G"; "Italics stand out.";  
30 LPRINT CHR$(27);CHR$(27);"%H"; "Back to normal."
```

```
○  
○ Everyday pica. Italics stand out. Back to normal. ○  
○  
○ ○
```



## Underlining

Function:

Code:

Start underlining

CHR\$(27);"-"; CHR\$(1)

Stop underlining

CHR\$(27);"-"; CHR\$(0)

Another way to emphasize a point is to underline it. Insert CHR\$(27);"-";CHR\$(1) to start underlining. Any characters that follow including spaces will be underlined until you send a CHR\$(27);"-";CHR\$(0) code.

```
10 LPRINT "Use underlining ";
20 LPRINT CHR$(27);"-";CHR$(1);"to emphasize a point.";
30 LPRINT CHR$(27);"-";CHR$(2);"Then return to normal."
```

```
○ Use underlining to emphasize a point. Then return to normal. ○
○
○
○
```

reduced by 85%

## Superscripts/ Subscripts

Function:

Start Superscript

Start Subscript

Return to normal print

Code:

CHR\$(27);"S";CHR\$(0)

CHR\$(27);"S";CHR\$(1)

CHR\$(27);"T"

2

With this feature, you can print half-size characters slightly above the printline (superscripts) for footnotes and exponents, or slightly below the printline (subscripts) for formulas. These characters always print in data processing mode, whether your standard characters are data processing or correspondence quality. For added compatibility with word processing systems, these two features cancel each other: a "start superscript" code returns subscripts to normal printing, and a "start subscript" command returns superscripts to normal print.

**NOTE:** *Super and subscripts continue until you stop them, even beyond the end of a line. Be sure to cancel these features before the end of a line, or line spacing will be thrown off.*

```
10 LPRINT "OKIMATE";CHR$(27);"S";CHR$(0);"TM"  
20 LPRINT CHR$(27);"T";"H";CHR$(27);"S";CHR$(1);"2";CHR$(27);"T";"O"
```

```
○  
○ OKIMATET M  
○ H2 O  
○
```

```
○  
○  
○  
○
```

## **IBM** ***character sets***

Function:

IBM character set 1

IBM character set 2

Code:

CHR\$(27);"7"

CHR\$(27);"6"

Your OKIMATE 20 will print either of IBM's two standard character sets. The major difference between Character Set 1 and Character Set 2 is that Character Set 1 has two control code numbers for certain non-printable codes. These extra numbers are used in some software packages. Character Set 2 offers a larger selection of European language characters. See the Charts below for the full character sets.

## CHARACTER SET 1

	0	1	2	3	4	5	6	7	8	9	A	B	C	D	E	F
0	NUL		SP	0	@	P	•	p	NUL		á	⋮	⊥	⊥	α	≡
1			!	1	A	Q	a	q			í	⋮	⊥	⊥	β	±
2		DC2	”	2	B	R	b	r		DC2	ó	⋮	⊥	⊥	Γ	≥
3			#	3	C	S	c	s			ú		⊥	⊥	π	≤
4		DC4	\$	4	D	T	d	t		DC4	ñ	⊥	—	⊥	Σ	↑
5			%	5	E	U	e	u			Ñ	⊥	⊥	⊥	σ	↓
6			&	6	F	V	f	v			ä	⊥	⊥	⊥	μ	÷
7	BEL		’	7	G	W	g	w	BEL		ö	⊥	⊥	⊥	τ	≈
8		CAN	(	8	H	X	h	x		CAN	ó	⊥	⊥	⊥	Φ	°
9	HT	EM	)	9	I	Y	i	y	HT	EM	⊥	⊥	⊥	⊥	θ	•
A	LF		*	:	J	Z	j	z	LF		⊥		⊥	⊥	Ω	-
B	VT	ESC	+	;	K	[	k	{	VT	ESC	½	⊥	⊥	■	δ	√
C	FF		,	<	L	\	l		FF		¼	⊥	⊥	■	∞	η
D	CR		—	=	M	]	m	}	CR		i	⊥	—	■	φ	²
E	SO		•	>	N	^	n	~	SO		<<	⊥	⊥	■	ε	■
F	SI		/	?	O	—	o	DEL	SI		>>	⊥	⊥	■	∩	SP

**Remarks :** In EP version, (20)<sub>H</sub> to (7E)<sub>H</sub>, (A0)<sub>H</sub> to (A8)<sub>H</sub>, and (AB)<sub>H</sub> to (AF)<sub>H</sub> have each CQ fonts. In MASK version, all the characters excluding (B0)<sub>H</sub> to (DF)<sub>H</sub>, (F4)<sub>H</sub> and (F5)<sub>H</sub> have each CQ fonts.

## CHARACTER SET 2

	0	1	2	3	4	5	6	7	8	9	A	B	C	D	E	F
0	NUL		SP	0	@	P	•	p	Ç	É	á	⋮	⊥	⊥	α	≡
1			!	1	A	Q	a	q	ü	æ	í	⋮	⊥	⊥	β	±
2		DC2	"	2	B	R	b	r	é	Æ	ó	⋮	⊥	⊥	Γ	≥
3	♥		#	3	C	S	c	s	â	ô	ú		†	⊥	π	≤
4	♦	DC4	\$	4	D	T	d	t	ä	ö	ñ	†	-	⊥	Σ	↑
5	♣	§	%	5	E	U	e	u	à	ò	Ñ	†	†	⊥	σ	↓
6	♠		&	6	F	V	f	v	å	û	ä	†	†	⊥	μ	÷
7	BEL		'	7	G	W	g	w	ç	ù	ó	⊥	†	†	τ	≈
8		CAN	(	8	H	X	h	x	ê	ÿ	¿	⊥	⊥	†	Φ	°
9	HT	EM	)	9	I	Y	i	y	ë	ö	⊥	†	⊥	⊥	θ	•
A	LF		*	:	J	Z	j	z	è	ü	⊥		⊥	⊥	Ω	-
B	VT	ESC	+	;	K	[	k	{	ï	ç	½	⊥	⊥	■	δ	√
C	FF		,	<	L	\	l		î	£	¼	⊥	†	—	∞	η
D	CR		-	=	M	]	m	}	ï	¥	ı	⊥	-	⊥	φ	²
E	SO		.	>	N	^	n	~	Ä	ƒ	«	⊥	†	⊥	€	■
F	SI		/	?	O	_	o	DEL	Å	f	>>	⊥	⊥	—	∩	SP

**Remarks :** In EP version group 1, (15)<sub>H</sub>, (21)<sub>H</sub> to (7F)<sub>H</sub>, (81)<sub>H</sub>, (82)<sub>H</sub>, (84)<sub>H</sub> to (86)<sub>H</sub>, (89)<sub>H</sub>, (8B)<sub>H</sub>, (8E)<sub>H</sub>, (8F)<sub>H</sub>, (90)<sub>H</sub> to (92)<sub>H</sub>, (94)<sub>H</sub>, (95)<sub>H</sub>, (99)<sub>H</sub>, (9A)<sub>H</sub>, (9C)<sub>H</sub>, (E1)<sub>H</sub> and (ED)<sub>H</sub> have each CQ fonts. In EP version group 2, (15)<sub>H</sub>, (21)<sub>H</sub> to (7F)<sub>H</sub>, (80)<sub>H</sub> to (83)<sub>H</sub>, (85)<sub>H</sub>, (87)<sub>H</sub> to (8B)<sub>H</sub>, (8D)<sub>H</sub>, (90)<sub>H</sub>, (93)<sub>H</sub>, (95)<sub>H</sub> to (98)<sub>H</sub>, (9A)<sub>H</sub>, (9C)<sub>H</sub> and (A1)<sub>H</sub> to (A3)<sub>H</sub> have each CQ fonts. In Mask version, all the characters excluding (B0)<sub>H</sub> to (DF)<sub>H</sub>, (F4)<sub>H</sub> and (F5)<sub>H</sub> have each CQ fonts.

By adjusting internal function switch #4 (See Appendix A.), your printer will enter a specific character set whenever you switch it on. (The factory has adjusted this switch to Character Set 1.)

If you want to switch character sets using programming commands, send a CHR\$(27);"6" code to enter Character Set 2 or to enter Character Set 1, use a CHR\$(27);"7" command.

## Line spacing

Function:	Code:
8 Lines Per Inch (1/8")	CHR\$(27);"0"
10.2 Lines Per Inch (7/72")	CHR\$(27);"1"
6 Lines Per Inch (1/6")	CHR\$(27);"A";"12";CHR\$(27);"2"
Set spacing at n/72" (n is less than 85)	CHR\$(27);"A";"n"
Activate n/72 spacing	CHR\$(27);"2"
Set spacing at n/216" (n is less than 255)	CHR\$(27);"3";"n"
Set spacing at n/216" (for one line only)	CHR\$(27);"J";"n"

OKIMATE normally prints 6 Lines Per Inch (LPI), that is, the distance from the bottom of one line to the bottom of the next is 1/6 inch. If you want to fit more lines on a page, use the 8 LPI command or the 10.2 LPI command.

```
10 FOR I = 1 TO 3
20 LPRINT "6 LPI - 1/6 INCH"
30 NEXT I
40 LPRINT CHR$(27);"0"
50 FOR J=1 TO 4
60 LPRINT "8 LPI - 1/8 INCH"
70 NEXT J
80 LPRINT CHR$(27);"1"
90 FOR K=1 TO 5
100 LPRINT "LINE SPACING AT 7/72 INCH"
110 NEXT K
```



Here's the printout:

```
○
○ 6 LPI - 1/6 INCH
○ 6 LPI - 1/6 INCH
○ 6 LPI - 1/6 INCH
○
○ 8 LPI - 1/8 INCH
○ 8 LPI - 1/8 INCH
○ 8 LPI - 1/8 INCH
○ 8 LPI - 1/8 INCH
○
○ LINE SPACING AT 7/72 INCH
○ LINE SPACING AT 7/72 INCH
○ LINE SPACING AT 7/72 INCH
○ LINE SPACING AT 7/72 INCH
○
○
```

## ***Fine line spacing***

For graphics or "special effects," try the fine line spacing commands, which change the spacing in multiples of 1/72 inch or 1/216 inch. This doesn't affect the height of the characters, only the space between the lines. For example, if you choose a fine line spacing of 72/72 inch, there would be 1 inch between the top of one line and the top of the next.

To print a document with line spacing in multiples of 1/72 inch, first use the CHR\$(27);"A";CHR\$(n) command, where n is the multiple you desire and is a number less than 85 and greater than 1. Then send a CHR\$(27);"2" command. This activates the fine line spacing set by the CHR\$(27);"A";CHR\$(n) command.

Use this command to return to 6 LPI by having n equal 12 (12/72 inch equals 1/6 inch line spacing).

```
10 FOR L=1 TO 4
20 LPRINT CHR$(27);"A";CHR$(8)
30 LPRINT CHR$(27);"2"
40 LPRINT "8/72 - USE FOR GRAPHICS"
50 NEXT L
60 LPRINT CHR$(27);"A";CHR$(12)
70 LPRINT CHR$(27);"2"
80 LPRINT "BACK TO"
90 LPRINT "6 LPI"
```

```
○ 8/72 - USE FOR GRAPHICS ○
○
○ 8/72 - USE FOR GRAPHICS ○
○
○ 8/72 - USE FOR GRAPHICS ○
○
○ 8/72 - USE FOR GRAPHICS ○
○
○ BACK TO ○
○ 6 LPI ○
```

If you just wrote line 30 without specifying a fine line spacing in line 20, the default spacing of 6 LPI is activated.

To set line spacing in multiples of 1/216 inch up to 255/216 inch, use the CHR\$(27);CHR\$(51);CHR\$(n) command. Here, n equals a number between 1 and 255.

This line spacing activates automatically when the printer receives this command.

(See "Programmer's Note.")\*

2

If you want to set the line spacing to a multiple of 1/216 inch up to 255/216 inch for one line only, use the CHR\$(27);"J";CHR\$(n) command. Again, n equals a number between 1 and 255. When OKIMATE 20 receives this command, it prints the line that contains it, and then advances the specified distance and prints the next line. Line spacing then returns to the previous setting. Be sure to place semicolons before and after this sequence, otherwise it will not work. (See "Programmer's Note.")\*

```
10 LPRINT CHR$(27);CHR$(51);CHR$(18)
20 FOR M=1 TO 6
30 LPRINT "SPACE 18/216 INCH = 1/12 INCH"
40 NEXT M
50 LPRINT CHR$(27);"A";CHR$(12);CHR$(27);"2"
60 LPRINT "BACK TO"
70 LPRINT "6 LPI"
80 LPRINT "THE NEXT LINE WILL BE";CHR$(27);CHR$(74);CHR$(18);
90 LPRINT "SPACED AT 18/216 INCH."
100 LPRINT "THEN OKIMATE 20 RETURNS"
110 LPRINT "TO NORMAL SPACING AT 6 LPI"
```

The printout looks like this:

```
○
○ SPACE 1800/216 INCH == 1/12 INCH ○
○ SPACE 1800/216 INCH == 1/12 INCH ○
○ SPACE 1800/216 INCH == 1/12 INCH ○
○ SPACE 1800/216 INCH == 1/12 INCH ○
○
○ BACK TO ○
○ 6 LPI ○
○ THE NEXT LINE WILL BE ○
○ SPACED AT 1872/16 INCH. ○
○ THEN OKIMATE 20 RETURNS ○
○ TO NORMAL SPACING AT 6 LPI ○
○
○
○
○
○
○
```

**Programmer's Note:** For mechanical reasons, OKIMATE 20 advances paper in multiples of 1/144 inch, not in multiples of 1/216 inch, which is the standard for IBM printers. To increase IBM compatibility, the printer multiplies the "n" value in your statements by 2/3 to approximate 1/216 inch. Because of rounding off, you may sometimes notice line spacing varies slightly from your specified statement. For more precise spacing, set your line spacing in multiples of 1/72 inch wherever possible.

## Line feed

Function:

Code:

Line feed

CHR\$(10)

When your OKIMATE 20 reaches the end of a line, it automatically advances to the next line (This is called a "line feed"). If, however, your programming needs require you to insert a line feed, CHR\$(10) does the job.

2

```
10 LPRINT "This is a ";CHR$(10)
20 LPRINT "Line feed."
```

*Programmer's Note:* A CHR\$(11) will also generate a line feed.

```
○ This is a ○
○           ○
○           ○
○ Line feed. ○
○           ○
○           ○
```

## Horizontal tabs

Function:	Code:
Advance to next tab	CHR\$(9)
Set specified tabs	CHR\$(27);"D";CHR\$(TAB1);CHR\$(TAB2)...CHR\$(0)

Like a typewriter, OKIMATE can advance by tabs across a line. Send a CHR\$(9) command to advance to the next stop. Your OKIMATE 20 has tab stops every 8 spaces. If you want to change the tab spacing use the tab set command:

```
CHR$(27);CHR$(68);CHR$(TAB1);CHR$(TAB2);...;CHR$(0)
```

Here TAB1, TAB2 and all other tabs indicate the column where you want the tab stops located. The CHR\$(0) tells the printer the tab loading is complete. While we've only listed TAB1 and TAB2 here, you can set up to 28 tab stops. The location of the right-most possible tab stop depends on what character size you're using:

Character size (regular & double wide)	Number of columns	
Pica:	10 CPI	80
	5 CPI	40
Elite:	12 CPI	96
	6 CPI	48
Condensed:	17.1 CPI	132
	8.5 CPI	66

Here's a sample program which sets tab stops every 20 spaces (in Pica print):

```
10 LPRINT CHR$(18);"Pica Printing"  
20 LPRINT CHR$(27);"D";CHR$(20);CHR$(40);CHR$(60);CHR$(80);CHR$(0)  
30 LPRINT CHR$(9);"Tab 1";CHR$(9);"Tab 2";CHR$(9);"Tab 3";CHR$(9);"Tab 4"
```



This is the printout:

```
○ Pica printing ○  
○  
○ Tab 1 Tab 2 Tab 3 Tab 4 ○  
○  
○  
○  
○
```

To clear all tab stops, use this command:

```
CHR$(27);"D";CHR$(0)
```



## ***Form feeds, page length***

Function:	Code:
Advance to top of next page	CHR\$(12)
Set page length lines = number of lines per page	CHR\$(27);"C";"lines" lines = 127 or less
Set page length inches = number of inches per page	CHR\$(27);"C";CHR\$(0);"lines" inches = 22 or less

Before you switch OKIMATE 20 on, advance the paper to the line you want OKIMATE to start printing. Once the power goes on, this line is your "top of form." When you advance to top of the next page, OKIMATE will start printing on that same line.

Advance one page: You can make the paper advance to the top of the next page (called a "form feed") by holding in the "SELECT" button for several seconds. You can also program your printer for a form feed by sending a CHR\$(12) command. The paper will advance to the next page's top of form.

Setting Page Length: Your printer automatically adjusts for paper that's 12 inches long (The size of a standard sheet of typewriter paper). If you want to print a page or form that's a different length, tell OKIMATE 20 by specifying a length in either inches or number of lines. To specify a page length in lines, use the CHR\$(27);"C";"lines" command. Remember, the number of lines per inch depends on your line spacing. If you have a 10 inch page and your line spacing is 6 Lines Per Inch, the page is 60 lines long.

If you had a 10 inch page and your line spacing was set at 8 lines per inch, and you wanted a 10 inch page which is 80 lines long, the command is:

```
CHR$(27);"C";"80"
```

If you want to set your page length according to inches, use the `CHR$(27); "C";CHR$(0);"inches"` command. You can set a page length up to 22 inches. For example, to set a page length at 14 inches, use this command in your program:

```
CHR$(27);"C";CHR$(0);"14"
```

2

## Perforation skipping

Function:	Code:
Start skipping	<code>CHR\$(27);"N";"lines"</code>
Stop skipping	<code>CHR\$(27);"O"</code>

To start skipping again, insert this statement in your program:

```
LPRINT CHR$(27);"N";CHR$(1)
```

**NOTE FOR EXPERTS:** Any one-digit number may be used in place of "1" in this statement.

## Cancel function

Function:	Code:
Cancel	<code>CHR\$(24)</code>

The cancel function erases any data not yet printed that's stored in your OKIMATE's memory. (All printable data received since the last carriage return is erased.) It also cancels the double-width command. All other control commands, however, remain in effect.

## ***Power-up features***

Now that you're more familiar with many of the printing features of your OKIMATE 20, let's take a closer look at the standard settings your printer offers when you first switch it on. Some of these features depend on the setting of the internal function switches described in Appendix A.

<b>Function</b>	<b>Setting</b>
Character width	According to DIP SW2 (10 or 17.1 CPI)
Line feed pitch	6 LPI
Skip over perforation	1 inch
Super/Sub script	Released
Slant	Released
Underlining	Released
APA graphics	Released
CQ/Draft mode	By DIP switch setting 6
Top of form	Power-on position
Double width char.	Reset
Left margin	Home position
Right margin	80th column
Char. set selection	According to DIP SW4 (set 1 or set 2)
Page length	According to DIP SW1 (11 or 12 inches)
Auto LF	According to DIP SW3
ON line/OFF line	ON line

*Depends on setting of function switch. See Appendix A.*



## Section 3 – ADVANCED PROGRAMMING

### Introduction

This section's for experienced programmers only. Don't read this until you've mastered the other programming features of OKIMATE 20 that we've described previously.

As the title implies, this section contains some of the more advanced programming features of OKIMATE 20's including custom-designed characters, graphics, and color printing. If you're not yet an expert, skip to Section 4 for now, and come back here when you feel you're ready for a challenge!

### Custom Characters

With the custom character feature, you're not limited to the letters, numbers and symbols you see on your keyboard. The OKIMATE 20 memory will store up to 64 characters that you've designed yourself. You can design special symbols used by your profession or even create an entire alphabet in a unique typeface.

A device called the downline loadable character generator (DLCG) creates and stores these characters. Remember, your custom characters are stored in volatile memory. That means if you switch off the power, the characters are erased, so if you have characters you want to keep, store them on disk and transmit them to your printer whenever you want to use them.

To design a custom character, you must first design the character or symbol as a dot pattern on a grid. Then, translate this pattern into numeric data OKIMATE 20 can understand. After that, you assign the new character to any of the printable keys on your keyboard. Finally, write a program that loads this information into your printer's memory, and, of course, save the program on your disk, so you'll have it when you want it.

#### ***Designing a character***

Each character you design will be printed in a grid pattern called a matrix. OKIMATE 20 prints characters in a matrix that is 18 dots wide and 14 dots high. We'll try a smiling character as an example. To start your character, map a square grid that's 18 columns wide by 14 rows high, with a dark line between the seventh and eighth row.

Next, we'll convert the dot pattern into a code that OKIMATE 20 understands. Two codes are sent for each column of data. To help you, we've broken each column in half along the dark line and assigned a numerical value to each row on the matrix. All you need to do is add up the values of the dots in each half-column, like this:

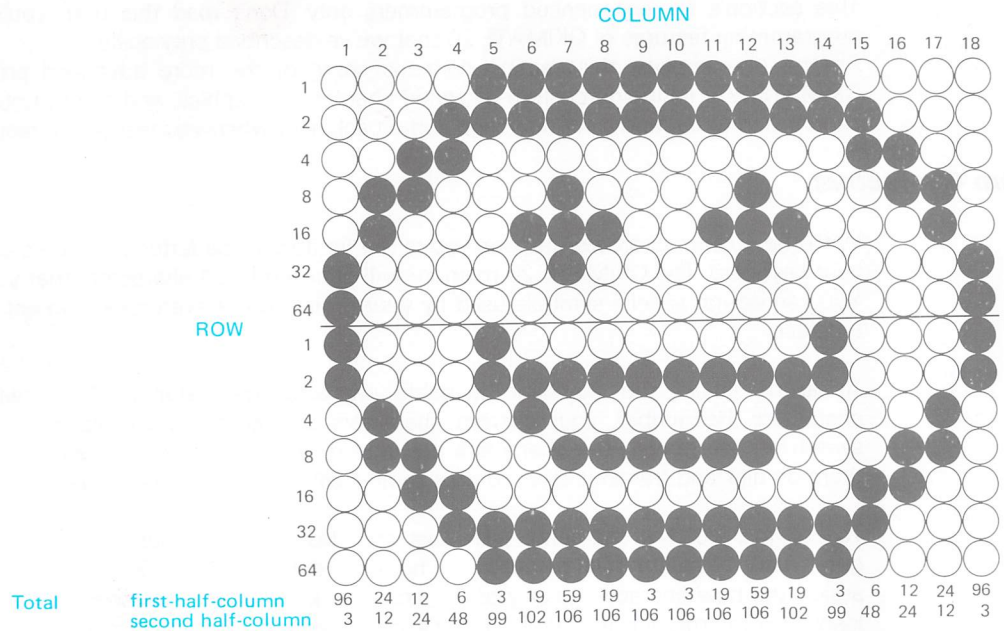

In column 1, for example, there are dots in rows 6 and 7 in the first half, for a total of 96, and rows 1 and 2 in the second half for a total of 3. Add the totals for all the columns.

## ***Ascenders and descenders***

We said the character matrix has 14 rows. This is true, sort of. You can print only 14 rows, but the matrix actually has 18 rows — four rows below the print line, which runs across the bottom of row 14. An “ascender” character prints in rows 1 through 14 and “sits” on the print line. Most characters are ascenders. “Descender” characters, including g, j, p, q, and y, have tails that descend below the print line, so they print in rows 4 to 18. If you want to print the same character as both ascender and descender, the numerical data for the columns would be the same, only the code sequences to load the data would differ.

## ***Loading the data***

Before executing DLL, be sure to load at least 3.5K bytes of NULL code (00)<sub>H</sub>. To start loading a character, first tell the printer you will be sending custom character data by sending this code:

```
CHR$(27);CHR$(1);CHR$(49)
```

This activates the downline character loading process.

Then, send a command which specifies whether you’re printing an ascender or a descender character. This command also tells the printer what standard keyboard character that your new character will replace. In this case, we’ll use the letter “m.” It could actually be any letter of the alphabet, upper or lower case, as well as your computer’s ASCII characters 64 through 127.

For ascenders, load this code:

```
CHR$(27);“%”;“A”;“m”;
```

For descenders, load this code:

```
CHR$(27);“%”;“D”;“m”;
```

Follow this code with the total you received when you added up the top half of column 1. Follow this with the total for second half of column 1. Then list the first and second halves of column 2, and continue this listing through column 18. This will give you a list of 36 numbers total.



For example, if we're loading our smile character, the program would look like this:

```
10 LPRINT CHR$(27);CHR$(1);CHR$(49);
20 FOR I= 1 To 35
30 LPRINT STRING$(100, CHR$(0));
40 NEXT I
50 LPRINT CHR$(27);"% A m";
60 LPRINT CHR$(96);CHR$(3);CHR$(24);CHR$(12);CHR$(12);CHR$(24);CHR$(6);
CHR$(48);CHR$(3);CHR$(99);CHR$(19);CHR$(102);CHR$(59);CHR$(106);
CHR$(19);CHR$(106);CHR$(3)CHR$(106);
70 LPRINT CHR$(3);CHR$(106);CHR$(19);CHR$(106);CHR$(59);CHR$(106);CHR$(19);
CHR$(102);CHR$(3);CHR$(99);CHR$(6);CHR$(48);CHR$(12);CHR$(24);
CHR$(24);CHR$(12);CHR$(96);CHR$(3);
```

Line 10 activates the character generator.

Line 20 to 40 loads 3.5K bytes of NULL code.

Line 50 determines your character will be an ascender character represented on the keyboard by "m."

Lines 60 and 70 contain the character data.

### ***Printing the character***

To print a custom character, first switch to the custom character set with this command:

```
CHR$(27);"%"; "Z"
```

After you've sent this command, whenever you enter the keyboard character which corresponds to your new custom character, the new character will print.

Add these lines to the "smile" program:

```
80 M$="m m m m m m m m m m m m m m m m m m m m m"
110 LPRINT CHR$(27);"%";"Z";M$
```

Line 110 switches to the custom character set and prints a line of smile.

Here's the printout

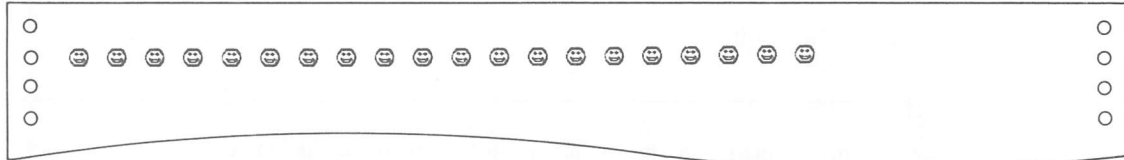

### ***Exiting the custom character set***

To exit the custom character set temporarily, use the `CHR$(27);"I";"2"` command to enter into standard correspondence quality mode, or `CHR$(27);"I";"1"` to enter the draft mode. To return to custom character mode, use the `CHR$(27);"%Z"` command.

To erase all custom characters from your OKIMATE 20 memory, use this command:

```
CHR$(27);CHR$(1);CHR$(0)
```

For an example of how these commands work, add these lines to your program:

```
90 LPRINT CHR$(27);"1";"2";M$  
100 LPRINT CHR$(27);"1";"1";M$  
110 LPRINT CHR$(27);"%" ;"Z";M$  
120 LPRINT CHR$(27);CHR$(1);CHR$(0);M$
```

3

Here's the result:

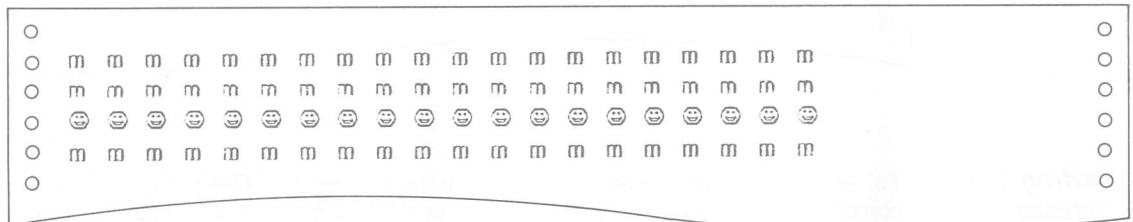

OKIMATE 20's graphics let you "draw" almost anything using your printer. Like a newspaper photograph, a graphic image printed by OKIMATE 20 is actually a pattern of tiny dots which produce a picture. Your program or software package tells OKIMATE 20 where to print each dot. Since even a simple drawing can be made up of thousands of individual dots, the easiest way for you to create illustrations is to use a graphics software package that manages all those dots for you. A software package usually let you create an image on your computer's screen and then "dumps" it onto a page.

This section tells you how to program graphic images on your own, without the aid of software packages. Using the methods described here, you can create programs for "drawing" charts, illustrations, decorative borders, and other graphics.

How does OKIMATE 20's graphics mode work? As you know, when you send an ASCII code in normal text mode, OKIMATE 20 will print a character (like A, &, or 3) or perform a non-printing function (like changing print size). But once you enter graphics mode, ASCII codes no longer stand for characters or non-printing commands, each code represents a unique pattern of dots in a single column.

For example, in normal printing, your OKIMATE 20 would print a CHR\$(65) code as the letter "A." In graphics mode, this code prints this dot pattern:



MSB: most significant bit

LSB: least significant bit

Graphic images are made up of many of these patterns. Like a combination of letters join to form words, a combination of these dot columns allow you to print pictures.

### ***Creating your graphics***

To give you greater flexibility in creating your graphics, OKIMATE 20 allows you to control the print resolution of your graphics by varying the number of dots per inch. There are five different resolutions, or "dot densities":

- Single density graphics — Prints standard graphics at  $60 \times 72$  Dots Per Inch. (For all computers)
- Double density graphics (normal speed) — Each dot column overlaps by about  $1/2$  dot width. Print density is  $120 \times 72$  DPI. (For PC only)

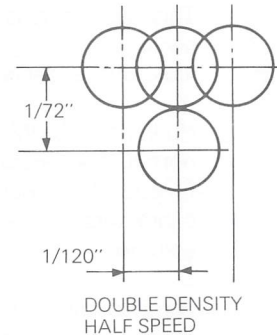

- Quadruple density graphics — Dot columns overlap by about  $3/4$  dot width. Restrictions: This mode can print only every other dot on the same row. Print density is  $240 \times 72$  DPI. (For PC only)

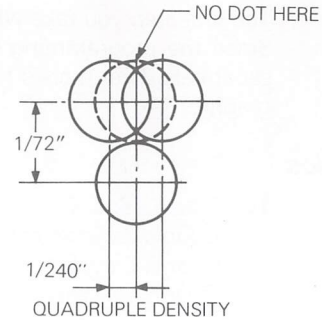

- 24-dot graphics — Other modes print only 8 dots per column. This mode uses all 24 of its printing elements to create a dot column pattern. Print density is  $120 \times 144$  DPI. (For PC only)

The first step you take when programming graphics is to map out your figure. Since the programming procedure for 24-dot graphics differs from the other modes, we'll discuss it separately. First, here's how to program images for single, double and quadruple density (8 dot high) graphics:

### **8-dot graphics**

#### **Function:**

#### **Code:**

Single density:

```
CHR$(27);"K";CHR$(n1);CHR$(n2);
```

Double density (normal):

```
CHR$(27);"L";CHR$(n1);CHR$(n2);
```

Double density (normal):

```
CHR$(27);"Y";CHR$(n1);CHR$(n2);
```

Quadruple density:

```
CHR$(27);"Z";CHR$(n1);CHR$(n2);
```

3

### **Mapping your (8-dot) character**

Before you start programming your graphic image, you must first map it out on a grid that's eight rows high and whatever number of dot columns wide you choose.

The width can't exceed these limits:

Single density	480-dot columns
Double density	960-dot columns
Quadruple density	1920-dot columns

As you're mapping out your image, remember the restrictions placed on the higher densities. You can only print every other dot in the same row.



Now onto an example. Suppose you wanted to draw two diagonal lines, like this:

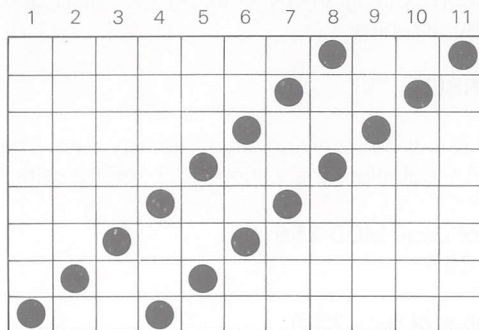

We've assigned values to each row of your grid. Whenever a dot appears in a row, add that value for a column total, like this:

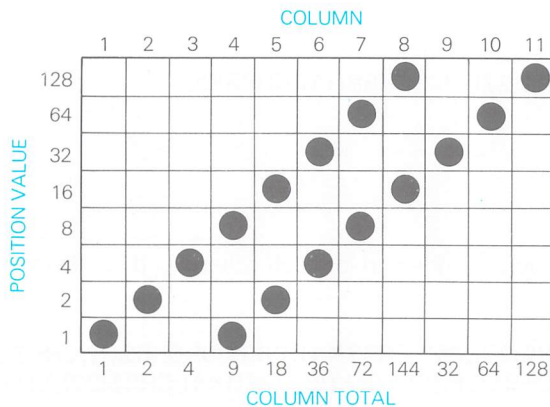

Use the column totals when writing your graphics program.

### Writing the program

Start your (8-dot) graphics program by entering the "start graphics" code. In this case, we'll use the code for single density graphics:

```
10 LPRINT CHR$(27);"K"
```

This tells the printer it will be receiving single density data. Then count the number of columns in the image; here, there's 11. Calculate the values of n1 and n2 using this equation:

```
n1 = (number of data) MOD 256  
    = 11 MOD 256  
    = 11  
n2 = INT (number of data/256)  
    = INT (11/256)  
    = 0
```

and add them to your statement:

```
10 LPRINT CHR$(27);"K";CHR$(11);CHR$(0);
```

Now take the values you've added up for each column and list them in the statement:

```
10 LPRINT CHR$(27);"K";CHR$(11);CHR$(0);CHR$(1);CHR$(2);CHR$(4);CHR$(9);  
    CHR$(18);CHR$(36);CHR$(72);CHR$(144);CHR$(32);CHR$(64);CHR$(128)
```

Now run the program. Here's the result:

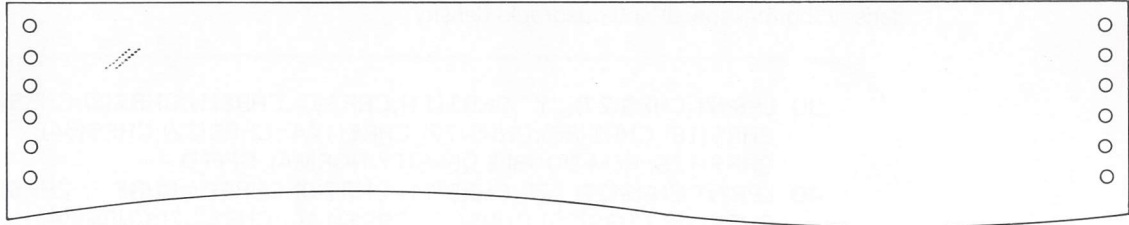

Now add another program line that uses double density, normal speed:

```
20 LPRINT CHR$(27);"L";CHR$(11);CHR$(0);CHR$(1);CHR$(2);CHR$(4);CHR$(9);  
CHR$(18);CHR$(36);CHR$(72);CHR$(144);CHR$(32);CHR$(64);CHR$(128)
```

Run these two lines and compare the result:

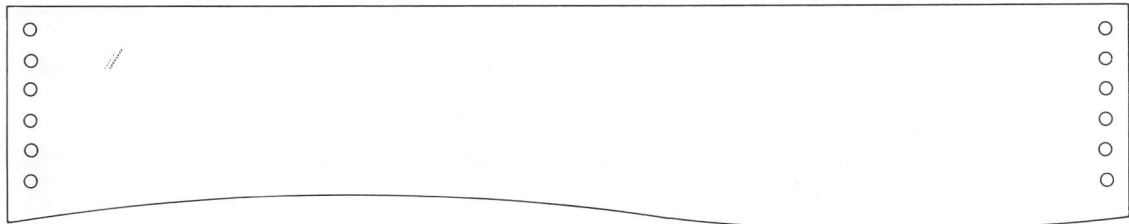

Notice the angle of the second graphic is steeper and the lines sit closer together. This is because each column of dots overlaps the next one. Now try a program lines with the command for double density (normal speed) and quadruple density:

```
30 LPRINT CHR$(27);"Y";CHR$(11);CHR$(0);CHR$(1);CHR$(2);CHR$(4);CHR$(9);  
CHR$(18);CHR$(36);CHR$(72);CHR$(144);CHR$(32);CHR$(64);  
CHR$(128):REM DOUBLE DENSITY/NORMAL SPEED  
40 LPRINT CHR$(27);"Z";CHR$(11);CHR$(0);CHR$(1);CHR$(2);CHR$(4);CHR$(9);  
CHR$(18);CHR$(36);CHR$(72);CHR$(144);CHR$(32);CHR$(64);  
CHR$(128):REM QUADRUPLE DENSITY
```

Now run the program:

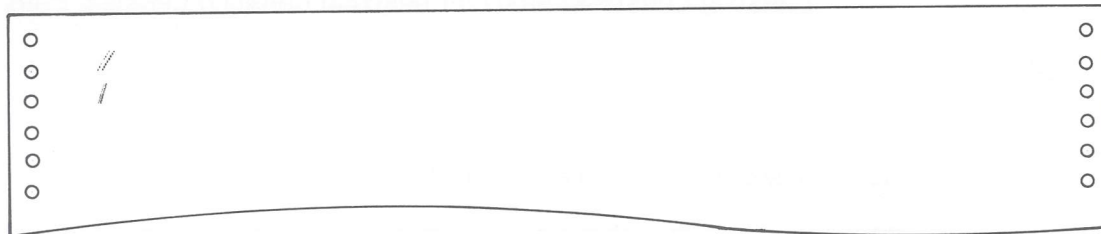

Notice that double density (normal speed) looks darker than double density (half speed). The angle of the lines, however, remains the same.

The quadruple density is steepest of all, and because of an even steeper overlap, the two diagonal lines have almost merged into one.

## 24-dot graphics

Start 24-dot graphics    `CHR$(27);"%";"O"CHR$(n1);CHR$(n2)`

When you map out a 24-dot graphic image, each column is 24 dots high. Each line can't be more than 960 dot columns wide.

This time, let's try a square as an example. Map it on a 24 by 24 grid like this:

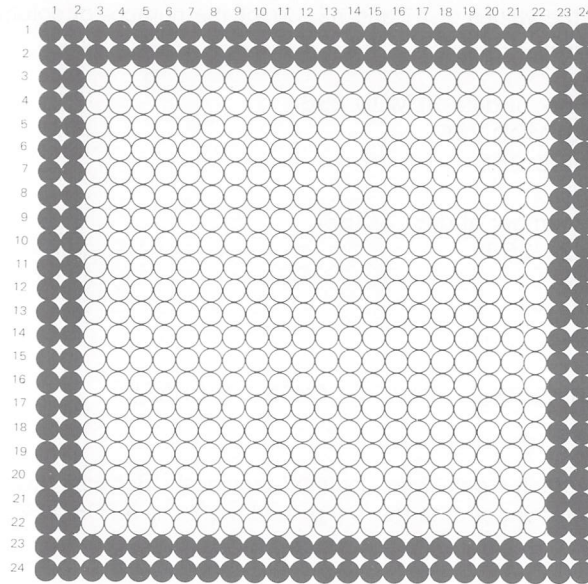

When you program 24-dot graphics, each dot column is defined with three values. Divide the grid into thirds and add up the totals:

You'll insert these totals later into your graphics program.

### Writing the program

Start your 24-dot graphics program with a line number, "LPRINT" statement and the 24-dot "Start graphics" code:

```
10 LPRINT CHR$(27);"%";"0";
```

Now calculate the values of n1 and n2. Count the number of columns in the image; here, there's 24. (number of data/3):

```
n1 = (number of data/3) MOD 256  
    = (72/3) MOD 256  
    = 24 MOD 256  
    = 24  
n2 = INT (number of data/3/256)  
    = INT (24/256)  
    = 0
```

Add these to the program:

```
10 LPRINT CHR$(27);"%";"0";CHR$(24);CHR$(0);
```

Then fill in the graphic data we calculated previously. Because there are 3 values for each column, e.g. there's a large amount of data that's repeated, we'll use a FOR/NEXT loop to repeat the graphic data:

```
10 LPRINT CHR$(27);"%";"0";CHR$(24);CHR$(0);
30 LPRINT CHR$(255);CHR$(255);CHR$(255);
40 FOR X = 1 TO 22
50 LPRINT CHR$(1);CHR$(0);CHR$(128);
60 NEXT X
70 LPRINT CHR$(255);CHR$(255);CHR$(255);
```

Here's the printout:

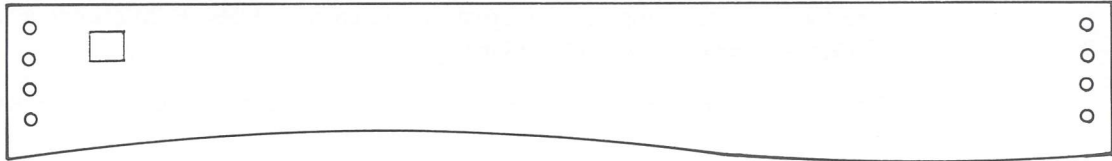



Function:	Code:
Align color ribbon	<code>CHR\$(27);CHR\$(25)</code>
Start new line	<code>CHR\$(13)</code>

You can write your own programs to print characters or graphics in color, but it's a rather complicated process. Here, we'll explain how your printer's color printing system works and how to use it in BASIC programs.

The color ribbon consists of three color strips — yellow, magenta (light red), and cyan (light blue) — plus a short black marker and a clear strip. OKIMATE 20 uses the black marker to align the ribbon. The color strips are for printing. OKIMATE 20's printhead passes over each line of print three times, once for each color strip. Like an artist mixing paints, OKIMATE 20 creates a wide range of colors mixing the three primary colors on the paper.

The first step in printing color is to remove the black ribbon and insert a color ribbon. Also remember the smoother the paper you use, the better the color production. Once you've inserted the color ribbon, you're ready to start programming.

Color printing programs must include these codes at the beginning of the first print statement:

```
CHR$(27);CHR$(25)
```

This tells OKIMATE 20 to search for the alignment marker and set the ribbon at the start of the first color (yellow). Anything printed in the next print statement will appear in yellow. The next print statement appears in magenta, and the third in cyan. At the end of the third print statement, add `CHR$(13)` to return the printhead and advance the paper to the next line. Your next print statement must begin with the ribbon alignment command — `CHR$(27);CHR$(25)`.

By choosing which colors you will or will not print on each line, you can mix combinations of the three basic colors to achieve a full spectrum of color choices.

```
10 LPRINT CHR$(27);CHR$(25);"YELLOW_____BLACK";CHR$(13);
20 LPRINT "_____MAGENTA_____BLACK";CHR$(13);
30 LPRINT "_____CYAN__BLACK";CHR$(13);CHR$(10);
40 LPRINT CHR$(27);CHR$(25);" _ORANGE___GREEN";CHR$(13);
50 LPRINT " _ORANGE_____PURPLE";CHR$(13);
60 LPRINT "_____GREEN__PURPLE";CHR$(13);CHR$(10);
```

3

<input type="radio"/>		<input type="radio"/>
<input type="radio"/>	YELLOW MAGENTA CYAN BLACK	<input type="radio"/>
<input type="radio"/>	ORANGE GREEN PURPLE	<input type="radio"/>
<input type="radio"/>		<input type="radio"/>
<input type="radio"/>		<input type="radio"/>
<input type="radio"/>		<input type="radio"/>
<input type="radio"/>		<input type="radio"/>
<input type="radio"/>		<input type="radio"/>
<input type="radio"/>		<input type="radio"/>

**NOTE:** The " \_ " symbol means press the space bar as often as it appears. For example, in line 10 you should press the space bar 15 times.

### ***Color shading (experts only)***

The program above printed seven colors. OKIMATE 20 isn't limited to these. By combining dot graphics and color printing, you can create a variety of hues.

The secret of creating these colors is to produce a checkered graphics pattern that combines color dots with white spaces.

When you print this pattern in color, you'll get a light shade of that particular color, since it combines both color and white. Printing a checkered red, for example, gives you a pink shade. By combining a light color with others, you can create more than two dozen colors.

The program below will give you a printout of 26 colors. It uses three subroutines to create solid blocks of color, checkered patterns, and white space. The data statement in line 260 lists the possible combinations of yellow, magenta, and cyan using these subroutines.

3

```
10 READ Y,M,C: REM GET DATA FOR YELLOW, MAGENTA, CYAN PATTERNS
20 LPRINT CHR$(27);"3";CHR$(24);
30 IF Y=0 THEN 40 ELSE 50
40 END
50 LPRINT CHR$(27);CHR$(25);:REM ALIGN RIBBON
60 ON Y GOSUB 130,190,250:REM SELECT PATTERN FOR YELLOW
70 ON M GOSUB 130,190,250:REM SELECT PATTERN FOR MAGENTA
80 ON C GOSUB 130,190,250:REM SELECT PATTERN FOR CYAN
90 LPRINT CHR$(10);
100 GOTO 110
110 GOTO 10:REM START NEW COLOR
120 LPRINT CHR$(27);"K";CHR$(224);CHR$(1);
130 FOR X=1 TO 480
140 LPRINT CHR$(255);:REM PRINT SOLID
150 NEXT X
160 LPRINT CHR$(13);
170 RETURN
180 LPRINT CHR$(27);"K";CHR$(224);CHR$(1);
190 FOR X=1 TO 80
200 LPRINT CHR$(85);CHR$(170);CHR$(85);CHR$(170);CHR$(85);CHR$(170);:REM
CHECKERED
210 NEXT X
220 LPRINT CHR$(13);
230 RETURN
240 LPRINT CHR$(13);
250 RETURN
260 DATA 1,1,1,2,1,1,3,1,1,2,2,1,3,1,2,2,3,1,3,2,1,3,3,1,3,2,2,3,3,2,1,2,1,2,1,2,2,2,
1,1,3,2,1,3,3,1,3,2,3,2,2,2,3,3,2,3,1,2,2,1,2,3,1,3,3,2,3,3,1,1,2,1,3,1,1,3,2,0,0,0
```



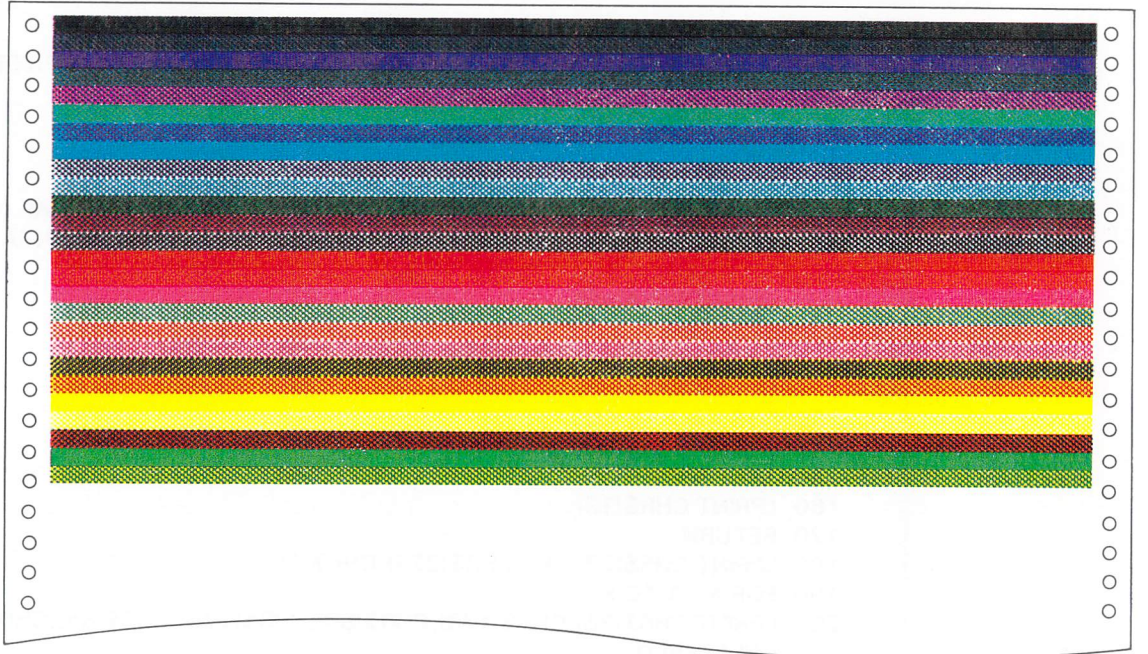

## Section 4 : **PRINTER CARE & TROUBLESHOOTING**

### **Introduction**

OKIMATE 20 needs little maintenance — only periodic cleaning to keep your printer up and running. If you do need extra help, the troubleshooting guide in this section should guide you through most problems with ease.

### **Cleaning Up**

Clean your OKIMATE 20's paper window with a clean, damp cloth whenever ink or dust starts to accumulate.

Clean the printhead after four ribbon changes or whenever you notice the print fading or missing print dots. If you've just finished using your printer, allow the printhead to cool before attempting to clean it. To clean the printhead, follow these steps:

- 1) Turn off the printer and unplug it. Allow the printhead to cool if the printer has been in use.
- 2) Open the paper and ribbon doors.

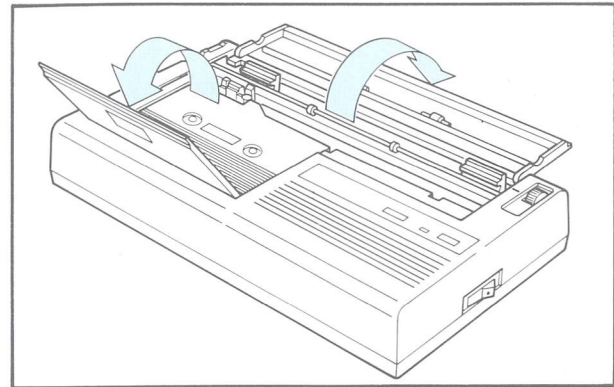

- 3) Remove the ribbon cartridge, returning the printhead to its upright position when it's removed.

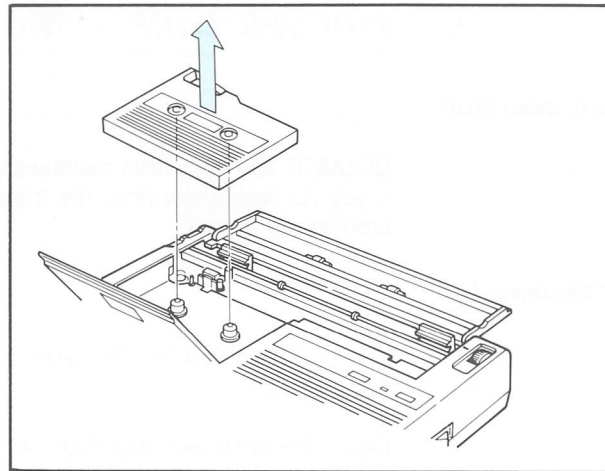

- 4) Unsnap the printhead lock lever, leaving the printhead carriage upright.

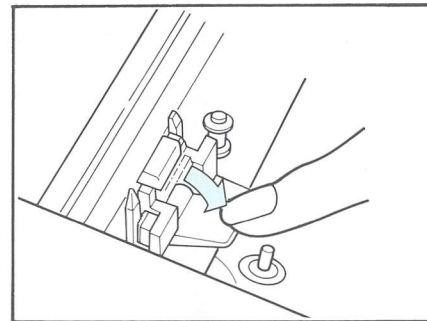



- 5) Pull back the tab on the top of the printhead carriage. Grasp the tab attached to the thermal printhead unit and lift it up.

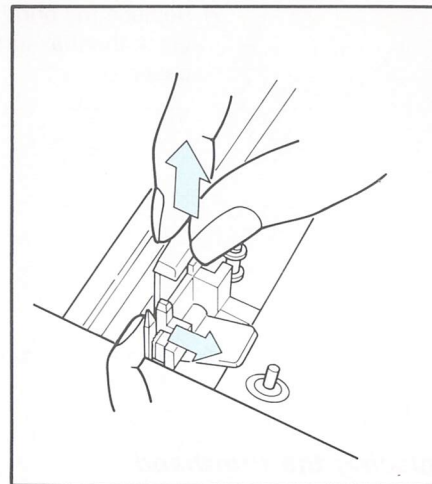

4

- 6) Wipe the dark surface of the printhead with a clean, lint-free cloth that has been moistened with alcohol or an alcohol-based typewriter cleaning solution. Wipe off all ink and paper lint.

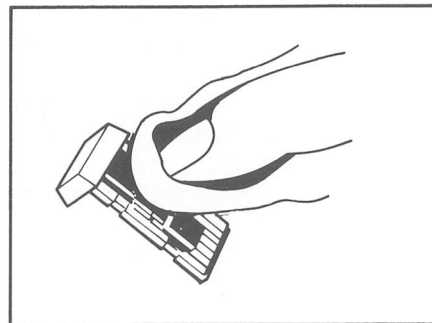

- 7) Replace the printhead — make sure the black thermal surface faces towards the paper.

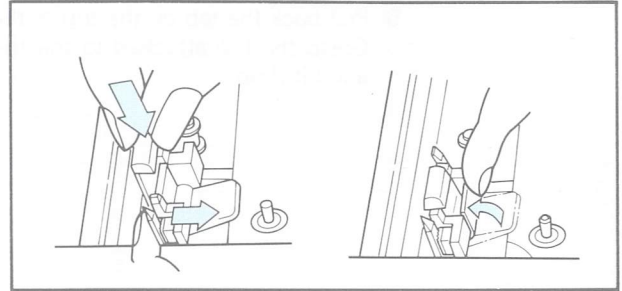

- 8) Replace the ribbon cartridge and close the paper and ribbon doors.

## Replacing the Printhead

If you notice that printed characters or graphics are not fully formed—with one or more dots consistently missing—your printhead may need replacing. Notice the row of dots missing near the bottom of these characters:

Clean the printhead first (following the directions on page 71 to 74), and, if problems still persist, replace the printhead.

To replace the printhead, remove it following the steps just described in “Cleaning Up.” Insert a new printhead in its place — making sure the dark thermal printhead side faces the paper and the printhead carriage is in its upright position.

Use this troubleshooting guide if you have any problems with your printer:

### What happens if...

#### *The printer doesn't work and the READY light is not on?*

Check the interface cable and the control module connections. Make sure both your printer and computer are switched on.

#### *The READY light blinks?*

Your printer is out of paper or ribbon. Replenish the supply and press the SELECT switch to clear the alarm.

#### *Printing becomes faded or blurred?*

The printhead needs cleaning. Follow the cleaning steps described in this handbook.

#### *One or more printing dots is consistently missing from printed characters and graphics, even after cleaning the printhead?*

The printhead needs to be replaced. Follow the steps outlined on page 71 to 74 of this handbook.

#### *The print ribbon becomes loose or tangled?*

Carefully remove the ribbon cartridge from the printer. Turn the thumb dial (located on the left side of the cartridge) counter-clockwise to take up the slack. Before reinserting, make sure the ribbon is not twisted.

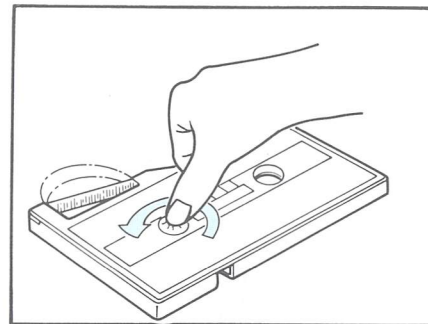

### *Paper feeds incorrectly?*

Adjust the paper guides so the outer marks match up with sprocket holes in computer paper. If you have single sheet or roll paper, adjust the paper guides so the edges of the paper match with the inner marks. (See page 14 and 19). Also, look at the black plastic rollers in the paper slot at the back of the printer. They should be about the same distance from the printer's sides as the two white rollers on the paper window. Slide them to the correct position.

### *I want to print graphics and pictures?*

"Paint" programs and drawing tablets make it easy to create pictures and charts of the screen. When you create a picture or chart with one of these drawing packages, the printer will copy the picture dot for dot in up to 16 colors. Simply draw the picture, save it on disk and use your printer's color print program to print it.

### *I forget to take the color ribbon out when printing text?*

Your document will be in a random variety of colors. If you want to print a document in a color other than black, it can be done, but you must follow the directions given on page 66.

## Appendix A : FUNCTION SWITCH SETTINGS AND INTERFACING

IBM compatible control modules for this printer are available in both parallel and serial interface versions. This appendix details the internal function switch settings needed for each of the versions, and also gives cabling requirements for both serial and parallel modules.

### Switch Settings

Your OKIMATE 20's function switches control features you're not likely to change often. Look on your printer's control module and locate near the module plug.

If your model has a parallel interface, there will be one panel of dip switches to the right of the plug. If you have a serial interface model, there will be two panels, one on either side of the plug.

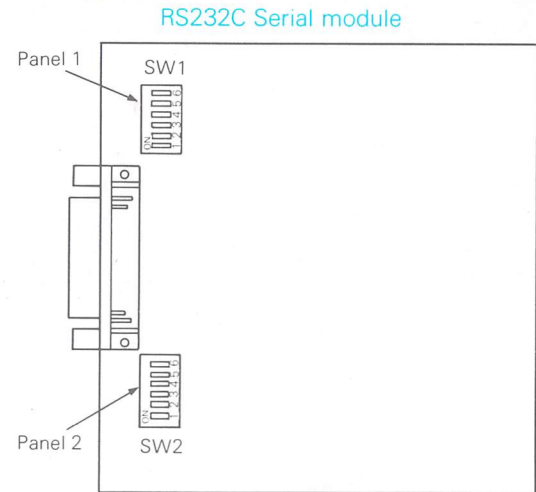
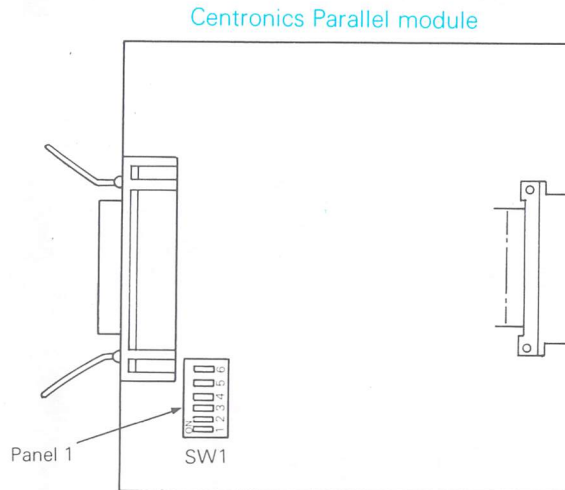

Panel 1 on parallel module and Panel 2 on serial module controls printing features. If you use certain features often, like a particular character set, you can adjust the switches on Panel 1 (for parallel) and Panel 2 (for serial) so when you turn on the printer, it automatically prints using these features. They become your printer's standard settings. Panel 1 (on serial interface module only) lets your meet the serial interface requirements of your computer.

### ***To set the function switches***

- 1) Switch your OKIMATE 20 OFF.
- 2) Disconnect the data cable from the printer and remove the module cover.
- 3) Remove the control module. (See page 19 and 26 for instructions).
- 4) Find Panel 1 (for Parallel) and Panel 2 (for Serial) on your control module. These panel are located to the right of the module plug. On serial interface models, Panel 1 is located to the left of the plug. These switches are numbered 1 to 6. By turning these switches ON or OFF, you control printer functions. Use the tip of a ball point pen or another pointed object to set the switches.

The chart below shows function switch settings (Panel 1 on parallel module and Panel 2 on serial module). Whenever you want a feature to come on automatically when the printer's power is switched on, set that switch to the appropriate position. For example, if you wanted OKIMATE to print in pica (10 CPI) print when it's switched on, turn switch #2 OFF.

Switch number	ON function	OFF function
#1	Form length 11 inches	Form length 12 inches
#2	17.1 CPI	10 CPI
#3	Auto LF ON	Auto LF OFF
#4	IBM character set #2	IBM character set #1
#5	Not used	Not used
#6	Data processing	Correspondence quality

After setting the function switches, replace the control module, access cover and data cable. Do not turn the printer on until the control module is inserted.



**Standard  
switch  
setting at  
delivery time**

**Panel 1 on parallel and Panel 2 on serial**

(1) In case of 220 VAC version

Switch No.	1	2	3	4	5	6
Setting	OFF	OFF	OFF	ON	OFF	OFF
Function	Form length 12 inches	10 CPI	AUTO LF OFF	Character set II	Not used	Correspondence quality

**Switch settings for IBM compatible control module (serial interface):**

If your OKIMATE 20 has a serial interface, you may have to adjust the switches on Panel 1 so the printer will meet the interface requirements of your computer. These switches are number 1 through 6.

(2) In case of 240 VAC version

Switch No.	1	2	3	4	5	6
Setting	ON	OFF	OFF	ON	OFF	OFF
Function	Form length 11 inches	10 CPI	AUTO LF OFF	Character set II	Not used	Correspondence quality

## **Switch settings for serial interface**

If your OKIMATE 20 has a serial interface, you may have to adjust the switches on Panel 1 so the printer will meet the interface requirements of your computer. These switches are number 1 through 6.

To determine how to set switches in Panel 1, answer the following questionnaire:

### **1. Which transmission speed will you be using?**

- a. 300 baud — Set switches 1 and 2 OFF. Go to question 2.
- b. 1200 baud — Set switch 1 ON and switch 2 OFF. Go to question 2.
- c. 4800 baud — Set switch 1 OFF and switch 2 ON. Go to question 2.
- d. 9600 baud — Set switches 1 and 2 ON. Go to question 2.

### **2. How is data being handled?**

- a. 7-bit with parity — Set switches 3 and 4 ON. (7-bit without parity is illegal.) Go to question 3.
- b. 8-bit with parity — Set switch 3 ON and 4 OFF. Go to question 3.
- c. 8-bit without parity — Set switch 3 and 4 OFF. Go to question 3.

### **3. What protocol are you using?**

- a. X-ON/X-OFF — Set switch 6 ON. Go to question 4.
- b. Printer Busy/Ready — Set switch 6 OFF. Go to question 5.

### **4. Is the system using odd or even parity?**

- a. Odd — Set switch 5 OFF. Switch setting is complete.
- b. Even — Set switch 5 ON. Switch setting is complete.

### **5. What signal does the computer recognize as a printer busy signal?**

- a. Busy = Low (–)      Ready = High (+)  
Set switch 5 ON. Switch setting is complete.
- b. Busy = High (+)      Ready = Low (–)  
Set switch 5 OFF. Switch setting is complete.

## Interfacing

### **Cable requirements**

There are several methods of making a cable to connect your OKIMATE 20 and computer. However, all of them require a level of knowledge in electronics — signals, wiring, soldering, crimping — to design properly.

The information given here will assist the experienced in identifying the printer's configuration and wiring requirements.

### **Parallel interfacing**

OKIMATE 20 requires a Centronics-equivalent parallel interface cable with the following:

- Amphenol 57-30360 or AMP 552274-1 (or equivalent) plug with 36 pins
- AMP 552073-1 (or equivalent) cover
- Beldon (or equivalent) shielded cable, maximum 5 1/2 yards, with twisted pair conductors, UL and CSA approved

#### **Connector pin arrangement**

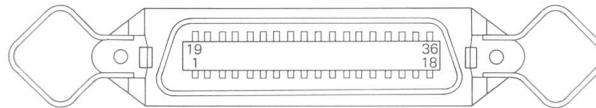

Here is an overview of the signals to be satisfied on the printer side:

Pin no.	Signal	Direction	Description
1	<u>DATA STROBE</u>	TO PRINTER	When this signal changes from low to high level, input data are sampled.
2	DATA BIT 1	TO PRINTER	Data lines. The high level represents '1', and the low level represents '0'.
3	DATA BIT 2		
4	DATA BIT 3		
5	DATA BIT 4		
6	DATA BIT 5		
7	DATA BIT 6		
8	DATA BIT 7		
9	DATA BIT 8		
10	<u>ACKNOWLEDGE</u>	FROM PRINTER	The low level of this signal indicates completion of data input or function operation.
11	BUSY	FROM PRINTER	The high level of this signal indicates that the printer cannot receive data. The low level of this signal indicates that the printer is ready for receiving data.
12	PAPER END	FROM PRINTER	The high level of this signal indicates that the paper has run out.
13	SELECT	FROM PRINTER	The high level of this signal indicates that the printer is in select (online) state.

Pin no.	Signal	Direction	Description
14,16,33	0 V	—	Signal ground
17	CHASSIS GROUND	—	Frame ground
18	+5 V	FROM PRINTER	+5 V supply (50 mA maximum)
19–30	0 V		Return for the twisted-pair wires of pins 1 to 11
31	$\overline{\text{INPUT PRIME}}$	TO PRINTER	When this signal goes to low level, the printer controller is initialized. The low level should be held for more than 0.5 ms.
32	$\overline{\text{FAULT}}$	FROM PRINTER	When the printer runs out of paper, this signal changes from high to low level.
15,34,35,36		—	Not used.

## Serial interfacing

OKIMATE 20 requires a RS232C serial interface cable with the following:

- AMP 2074624-2 (or equivalent) plug with 25 pins
- Beldon (or equivalent) shielded cable, maximum 5 1/2 yards, with twisted pair conductors, UL and CSA approved

### Connector pin arrangement

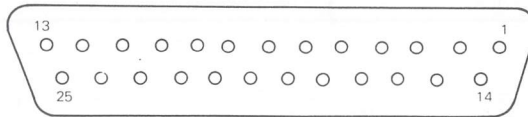

Pin No.	Signal	Symbol	Direction	Description
1	Protective ground	PG	—	Connected to printer frame
2	Transmitted data	TD	From printer	Serial data signal received transmitted by printer
3	Received data	RD	To printer	Serial data signal received by printer
4	Request to send	RTS	From printer	Transmission request signal from printer. SPACE during transmission.
5-6				Not used
7	Signal ground	SG	—	Signal ground
8-10				Not used

Pin No.	Signal	Symbol	Direction	Description
11	Supervisory send data	SSD	From printer	Signal to indicate that the printer is ready for receiving data.
12–19				Not used
20	Data terminal ready	DTR	From printer	Signal to indicate that the printer is ready for receiving data.
21–25				Not used



## Appendix B – SPECIFICATIONS

### Print method

Method	Thermal transfer dot matrix Thermal (heat sensing)
Format	Unidirectional printing

### Characters

Character Quality	Correspondence quality (CQ) Data processing (DP)
Character Size	DP — 7H×14V dots CQ — 14H×14V dots
Character Pitches	Pica print — 10 CPI*; 80 CPL** Elite print — 12 CPI; 96 CPL Fine print — 17.1 CPI; 132 CPL Double pica — 5 CPI; 40 CPL Double elite — 6 CPI; 48 CPL Double fine — 8.5 CPI; 66 CPL * CPI = Characters Per Inch ** CPL = Characters Per Line
Line Spacing	6 lines per inch 8 lines per inch Multiples of 1/216 inch
Character Sets	ASCII with or without zero slash, Spanish, IBM character set 1, IBM character set 2
Alternate fonts	Italics, superscript, subscript

### Graphics

Density	120×144 Dots Per Inch
Line Spacing	14/144 inch or variable n/144

### Speed

Text	DP mode — 80 CPS* CQ mode — 40 CPS
Graphics	60 CPS * CPS = Characters Per Second
24-dot graphics	40 CPS

### Paper

Type	Plain or thermal
Paper Feed	Pin feed for computer paper and friction feed for single sheets or roll paper. 127 to 254 mm
Width	Paper out detector
Special Features	Top of Page setting with automatic top and bottom margins on computer paper ("Skip over perforation") Optional roll paper stand

### Printhead

Print Elements	24
Dot Type	Dot size varies with speed and print darkness adjustment
Replacement	Snap-in. No tools required.

### Ribbon

Type	Black or color Single-strike
Cartridge	Easy load, "clean hands" type
Ribbon Life	120K characters or about 75 average pages in black About 35K characters or 10 screen prints in color
Special Features	Ribbon near-end detector Ribbon-saving (black ribbon) — ribbon does not advance when multiple "spaces" are printed.

App.

### Controls

Power	ON/OFF switch
Select	PAUSE/RESTART push button
Ready Lamp	Indicates ready/not ready to print
Print Darkness	Slide switch
Paper Handling	Typewriter-like paper release lever, paper advance knob and paper margin guides

### Color

Ribbon	3 colors
Text	7 colors
Color Graphics	40-50 or more

### Physical

Size	330(L) × 190(W) × 60(H)mm 13(L) × 7.5(W) × 2.36(H)inch
Weight	2.8 kg
Power	220 volts AC, 40 VA or 240 volts AC, 40 VA

### Interface

Type	Centronics parallel RS232C serial
------	--------------------------------------

## APPENDIX C: PROGRAMMER'S GUIDE

This chart provides you with a quick reference to the programming commands described in this handbook. For most programming uses, you'll need only the decimal code commands listed below. Ignore the hexadecimal and ASCII codes unless you have special programming needs. Check the programming section of this handbook for further explanations of each of the commands.

Function	Decimal	Hexadecimal	ASCII code
<b>Character size:</b> Changes size of printed characters (page 26).			
Pica (10 CPI)	(18)	(12)	DC2
Elite (12 CPI)	(27)(58)	(1B)(3A)	ESC:
Condensed (17.1 CPI)	(15)	(0F)	SI
<b>Double-width:</b> Doubles the width of current character size (page 27).			
One line only	(14)	(0E)	SO
Cancel	(20)	(14)	DC4
Continuous	(27)(87)(1)	(1B)(57)(01)	ESC W SOH
Cancel	(27)(87)(0)	(1B)(57)(00)	ESC W NUL
<b>Print quality:</b> Changes quality of printout (page 29).			
Data processing	(27)(73)(49)	(1B)(49)(31)	ESC I "1"
Correspondence quality	(27)(73)(50)	(1B)(49)(32)	ESC I "2"
<b>Italics:</b> Slants characters for emphasis (page 30).			
Start italics	(27)(37)(71)	(1B)(25)(47)	ESC % G
Stop italics	(27)(37)(72)	(1B)(25)(48)	ESC % H
<b>Underlining:</b> Underlines all characters (page 31).			
Start underline	(27)(45)(1)	(1B)(2D)(01)	ESC - SOH
Stop underline	(27)(45)(0)	(1B)(2D)(00)	ESC - NUL

Function	Decimal	Hexadecimal	ASCII code
<b>Super/subscripts:</b> Prints small characters above or below print line (page 32).			
Start superscript	(27)(83)(0)	(1B)(53)(00)	ESC S NUL
Start subscript	(27)(83)(1)	(1B)(53)(01)	ESC S SOH
Normal printing	(27)(84)	(1B)(54)	ESC T
<b>IBM character sets:</b> Prints one of two IBM character sets (page 33).			
IBM character set 1	(27)(55)	(1B)(37)	ESC 7
IBM character set 2	(27)(54)	(1B)(36)	ESC 6
<b>Line spacing:</b> Changes the number of lines per inch (page 36).			
8 lines per inch	(27)(48)	(1B)(30)	ESC 0
17.1 line spacing	(27)(49)	(1B)(31)	ESC 1
Set spacing a n/72" (n is less than 85)	(27)(65)"n"	(1B)(41)	ESC A "n"
Activate n/72" spacing	(27)(50)	(1B)(32)	ESC 2
Set spacing at n/216" (n is less than 255)	(27)(51)"n"	(1B)(33)"n"	ESC 3 "n"
Set spacing at n/216" (for one line only)	(27)(74)"n"	(1B)(4A)"n"	ESC J "n"
<b>Line feed:</b> Advances paper one line (page 42).			
Line feed	(10)	(0A)	LF
<b>Horizontal tabs:</b> Sets tab stops (page 43).			
Advance to next tab	(9)	(89)	HT
Set specified tabs	(27)(68)(TABS)(0)	(1B)(44)(TABS)(00)	ESC D "TABS" NUL
<b>Page formatting:</b> Sets page size (page 45).			
Advance to next page	(12)	(0C)	FF
Set page length in lines (lines = 1 to 127 lines per page)	(27)(67)"lines"	(1B)(43)"lines"	ESC C "lines"
Set page length in inches (inch = 22 or less)	(27)(67)(0)"inch"	(1B)(43)(00)"inch"	ESC C NUL "inch"
<b>Perforation skipping:</b> Controls skip over perforation (page 46).			
Start skipping	(27)(78)(1)	(1B)(4E)(01)	ESC N SOH
Stop skipping	(27)(79)	(1B)(4F)	ESC 0

Function	Decimal	Hexadecimal	ASCII code
<b>Cancel function:</b> Clears print memory (page 46).			
Cancel	(24)	(18)	CAN
<b>Custom characters:</b> (See page 49).			
<b>(Loading custom characters)</b>			
Start loading	(27)(1)(1)	(1B)(01)(01)	ESC SOH SOH
Load ascenders	(27)(37)(65)"m"	(1B)(25)(41)"m"	ESC % A "m"
Load descenders (m = replacement character)	(27)(37)(68)"m"	(1B)(25)(44)"m"	ESC % D "m"
<b>(Printing custom characters)</b>			
Enter custom mode	(27)(37)(90)	(1B)(25)(5A)	ESC % Z
Exit custom mode	(27)(1)(0)	(1B)(01)(00)	ESC SOH NUL
<b>Graphics:</b> (See page 55).			
Single density	(27)(75)(n1)(n2)	(1B)(4B)(n1)(n2)	ESC K n1 n2
Double density (normal speed)	(27)(76)(n1)(n2)	(1B)(4C)(n1)(n2)	ESC L n1 n2
Double density (normal speed)	(27)(89)(n1)(n2)	(1B)(59)(n1)(n2)	ESC Y n1 n2
Quadruple density	(27)(90)(n1)(n2)	(1B)(5A)(n1)(n2)	ESC Z n1 n2
24-dot graphics	(27)(37)(79)(n1)(n2)	(1B)(25)(4F)(n1)(n2)	ESC % 0 n1 n2
<b>Color programming:</b> (See page 66).			
Align ribbon	(27)(25)	(1B)(19)	ESC EM
Start new line	(13)	(0D)	CR





## Quick Reference

Function	Decimal	Hexadecimal	ASCII code
<b>Character size:</b>			
Pica (10 CPI)	(18)	(12)	DC2
Elite (12 CPI)	(27)(58)	(1B)(3A)	ESC:
Condensed (17.1 CPI)	(15)	(0F)	SI
<b>Double-width:</b>			
One line only	(14)	(0E)	SO
Cancel	(20)	(14)	DCA
Continuous	(27)(87)(1)	(1B)(57)(01)	ESC W SOH
Cancel	(27)(87)(0)	(1B)(57)(00)	ESC W NULL
<b>Print quality:</b>			
Data processing	(27)(73)(49)	(1B)(49)(31)	ESC I "1"
Correspondence quality	(27)(73)(50)	(1B)(49)(32)	ESC I "2"
<b>Italics:</b>			
Start italics	(27)(37)(71)	(1B)(25)(47)	ESC % G
Stop italics	(27)(37)(72)	(1B)(25)(48)	ESC % H
<b>Underlining:</b>			
Start underline	(27)(45)(1)	(1B)(2D)(01)	ESC - SOH
Stop underline	(27)(45)(0)	(1B)(2D)(00)	ESC - NULL
<b>Super/subscripts:</b>			
Start superscript	(27)(83)(0)	(1B)(53)(00)	ESC S NULL
Start subscript	(27)(83)(1)	(1B)(53)(01)	ESC S SOH
Normal printing	(27)(84)	(1B)(54)	ESC T
<b>IBM character sets:</b>			
IBM character set 1	(27)(55)	(1B)(37)	ESC 7
IBM character set 2	(27)(54)	(1B)(36)	ESC 6
<b>Line spacing:</b>			
8 lines per inch	(27)(48)	(1B)(30)	ESC 0
17.1 line spacing	(27)(49)	(1B)(31)	ESC 1
Set spacing a n/72" (n is less than 85)	(27)(65)"n"	(1B)(41)	ESC A "n"
Activate n/72" spacing	(27)(50)	(1B)(32)	ESC 2
Set spacing at n/216" (n is less than 255)	(27)(51)"n"	(1B)(33)"n"	ESC 3 "n"
Set spacing at n/216" (for one line only)	(27)(74)"n"	(1B)(4A)"n"	ESC J "n"
<b>Line feed:</b>			
Line feed	(10)	(0A)	LF





Function	Decimal	Hexadecimal	ASCII code
<b>Horizontal tabs:</b>			
Advance to next tab	(9)	(89)	HT
Set specified tabs	(27)(68)(TABS)(0)	(1B)(44)(TABS)(00)	ESC D "TABS" NUL
<b>Page formatting:</b>			
Advance to next page	(12)	(0C)	FF
Set page length in lines (lines = 11 to 127 lines per page)	(27)(67)"lines"	(1B)(43)"lines"	ESC C "lines"
Set page length in inches (inch = 22 or less)	(27)(67)(0)"inch"	(1B)(43)(00)"inch"	ESC C NUL "inch"
<b>Perforation skipping:</b>			
Start skipping	(27)(78)(1)	(1B)(4E)(01)	ESC N SOH
Stop skipping	(27)(79)	(1B)(4F)	ESC 0
<b>Cancel function:</b>			
Cancel	(24)	(18)	CAN
<b>Custom characters: (Loading custom characters)</b>			
Start loading	(27)(1)(1)	(1B)(01)(01)	ESC SOH SOH
Load ascenders	(27)(37)(65)"m"	(1B)(25)(41)"m"	ESC % A "m"
Load descenders (m = replacement character)	(27)(37)(68)"m"	(1B)(25)(44)"m"	ESC % D "m"
<b>(Printing custom characters)</b>			
Enter custom mode	(27)(37)(90)	(1B)(25)(5A)	ESC % Z
Exit custom mode	(27)(1)(0)	(1B)(01)(00)	ESC SOH NUL
<b>Graphics:</b>			
Single density	(27)(75)(n1)(n2)	(1B)(4B)(n1)(n2)	ESC K n1 n2
Double density (normal speed)	(27)(76)(n1)(n2)	(1B)(4C)(n1)(n2)	ESC L n1 n2
Double density (normal speed)	(27)(89)(n1)(n2)	(1B)(59)(n1)(n2)	ESC Y n1 n2
Quadruple density	(27)(90)(n1)(n2)	(1B)(5A)(n1)(n2)	ESC Z n1 n2
24-dot graphics	(27)(37)(79)(n1)(n2)	(1B)(25)(4F)(n1)(n2)	ESC % 0 n1 n2
<b>Color programming:</b>			
Align ribbon	(27)(25)	(1B)(19)	ESC EM
Start new line	(13)	(0D)	CR







**COMMODORE BUSINESS MACHINES PTY. LTD.**

67 Mars Road, Lane Cove  
New South Wales, Australia

Distributors and/or dealers/retailers in your cities: